

TOP VIEW

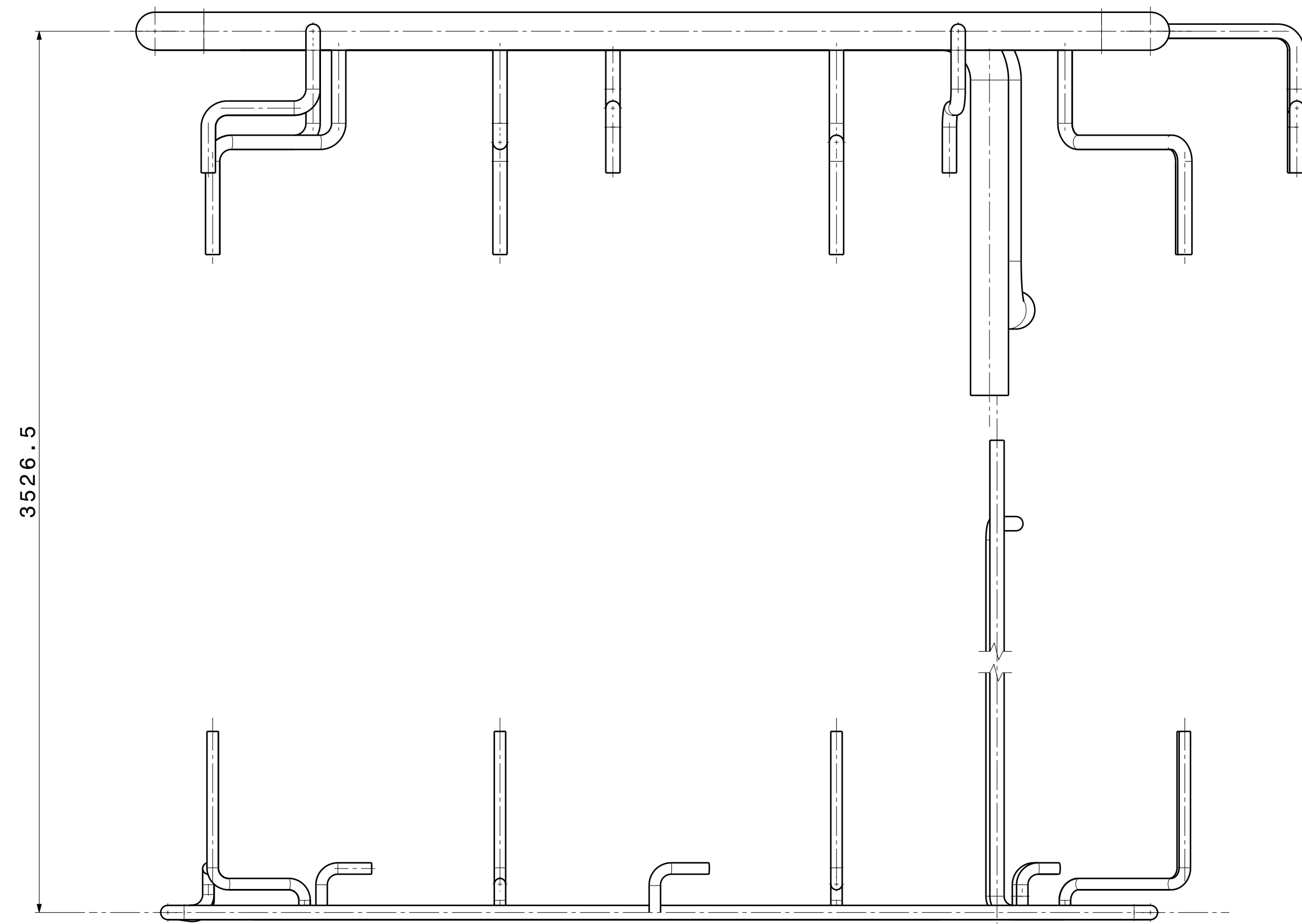

FRONT VIEW

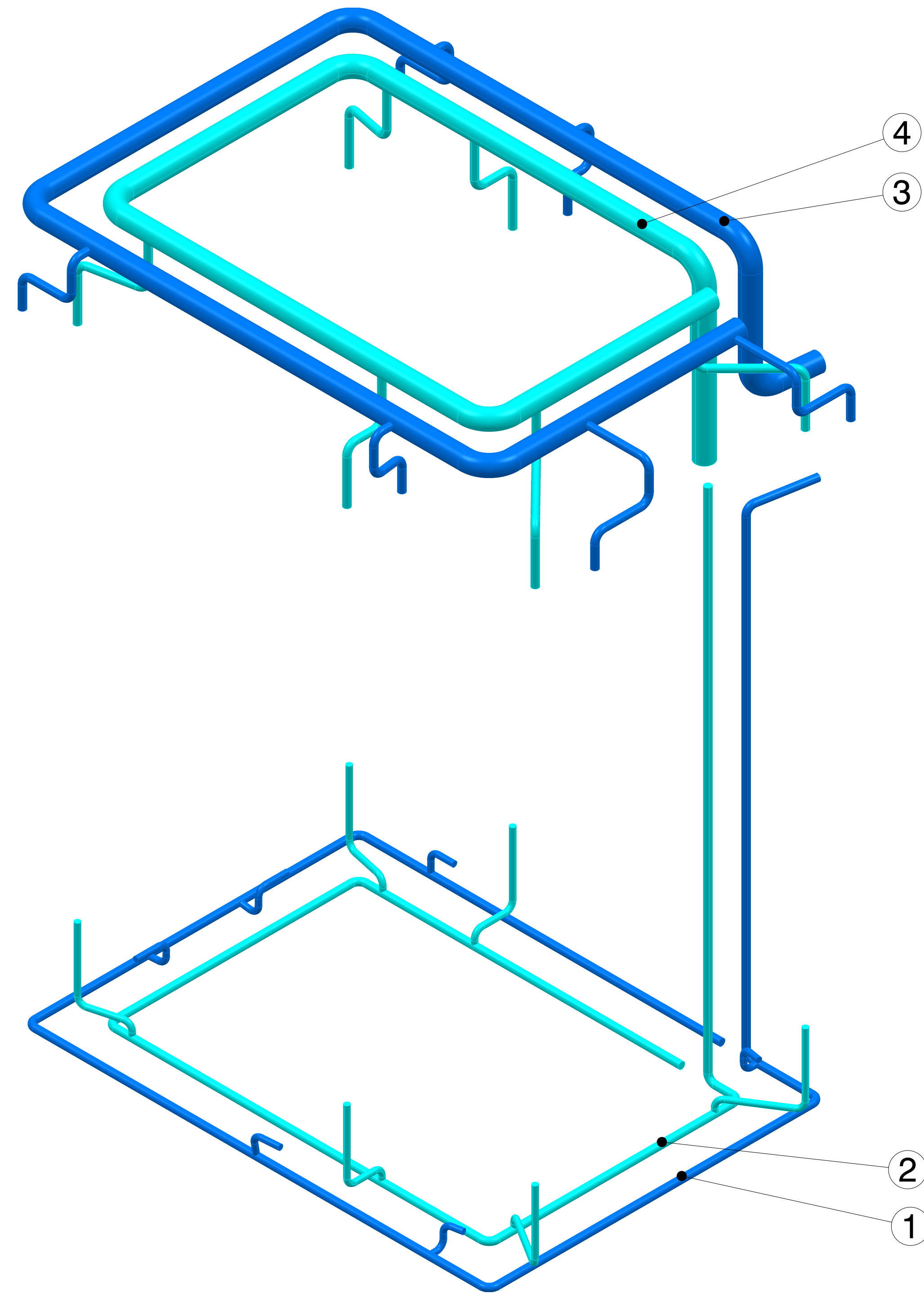

ISOMETRIC VIEW

NOTE:-  
1. ALL THE REQUIRED PIPES STANDARD BENDS  
WILL BE GIVEN AS FREE ISSUE MATERIAL.

PART NO.	DESCRIPTION	QTY.
1	NITROGEN SUPPLY HEADER	1
2	HELIUM SUPPLY HEADER	1
3	NITROGEN RETURN HEADER	1
4	HELIUM RETURN HEADER	1

DRG. NO	▽ 8-25	▽▽ 1.6-8	▽▽▽ 0.025-1.6	▽▽▽▽ < 0.025	REVISION COLUMN				NBI GROUP:	SIZE	INSTITUTE FOR PLASMA RESEARCH				
CO-ORDINATED BY					REV	ZONE	DESCRIPTION	DATE	REMARKS	APPROVED BY	ALL DIMENSIONS ARE IN 'mm' UNLESS OTHERWISE STATED	A3	BHAT, GANDHINAGAR-382 428.		
MACHINING DEVIATIONS FOR NON-TOLERANCED DIMENSIONS															
LENGTH IN mm OF SHORTER SIDE OF ANGLES				LENGTH OR DIA	UPTO 6	6-30	30-120	120-315					SCALE	DATE	
UPTO 10	10-50	50-120	OVER 120-400		±0.1	±0.2	±0.3	±0.5					DRAWN	ARK	
+1'	+0'-30'	+0'-20'	+0'-10'										DESIGNED		
											APPROVED		REF DRG NO:	REV RD	
													DRG. NO	2.04.02.039	SHEET 01 OF 03