

Section view G-G

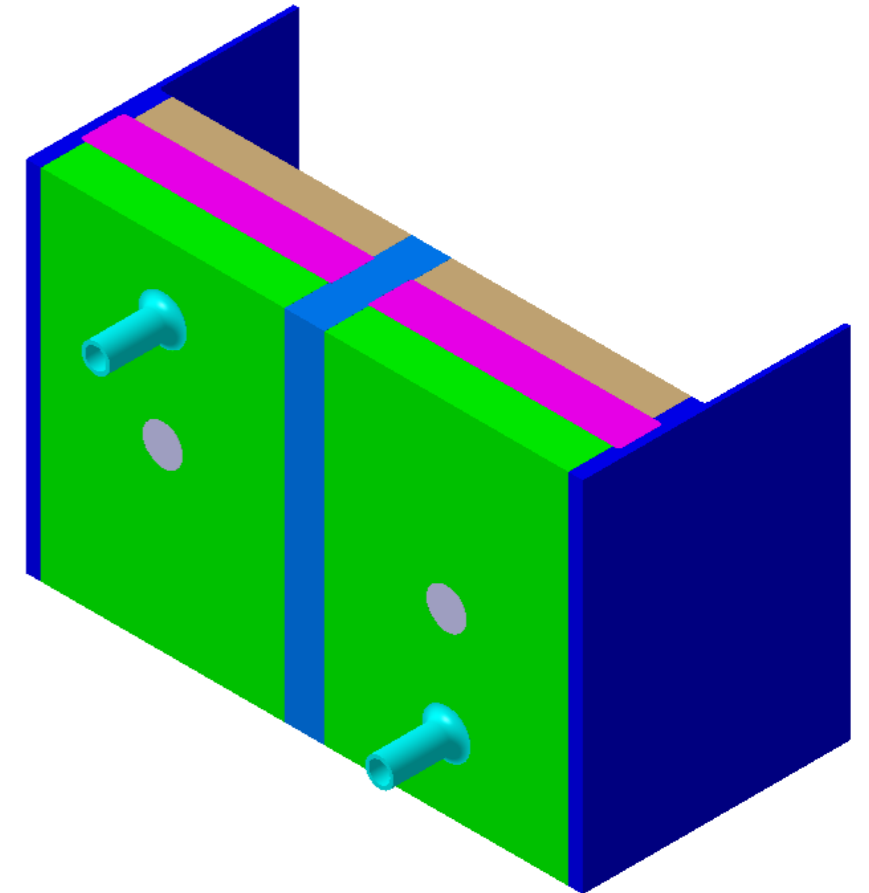

Isometric view

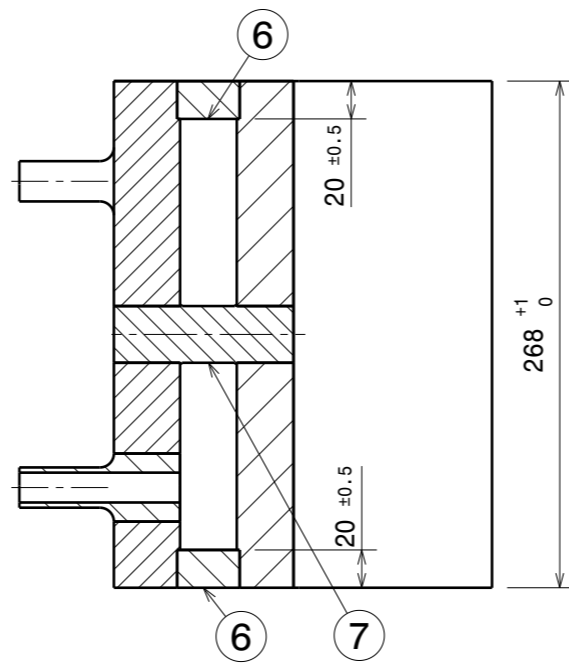
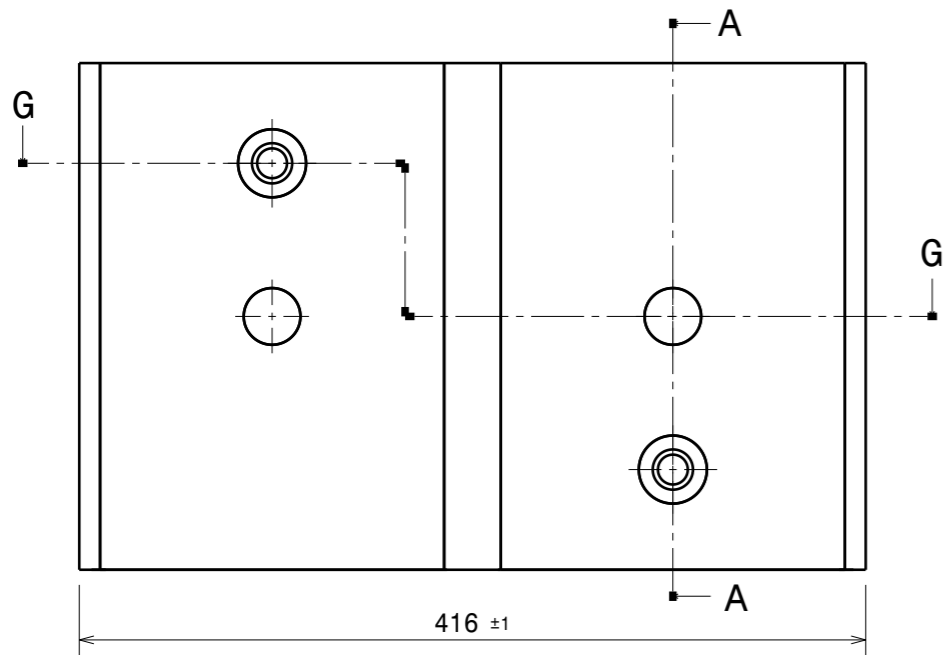

Section view A-A

1. THE PLATES SHALL BE PRE-MACHINED TO ACHIEVE DIMENSIONAL ACCURACY.
2. REPAIR OF ANY DEFFECT BY WELDING IS NOT PERMITTED.
3. GENERAL TOLERANCE OF $\pm 0.3\text{mm}$ IF NOT MENTIONED.
4. DIMENSIONS GIVEN IN BRACKET (XX) REFER AS REFERENCE DIMENSION.
5. DIMENSIONS INDICATE BY * REFER AS REPEAT DIMENSIONS.

PART NO	DRAWING NO	PART NAME	QTY.	MATERIAL
7	BKPA_IPR_01_7	STIFFNER_PIN	2	ASTM-182 F91
6	BKPA_IPR_01_6	COVER PLATE	4	ASTM-387 GR.91 CLASS 2
5	BKPA_IPR_01_5	PIPE	2	ASTM-182 F91
4	BKPA_IPR_01_4	MID PLATE	1	ASTM-387 GR.91 CLASS 2
3	BKPA_IPR_01_3	OUTER BACK PLATE	2	ASTM-387 GR.91 CLASS 2
2	BKPA_IPR_01_2	INNER BACK PLATE	2	ASTM-387 GR.91 CLASS 2
1	BKPA_IPR_01_1	SIDE PLATE	2	ASTM-387 GR.91 CLASS 2

REVISION COLUMN					
REV	ZONE	DESCRIPTION	DATE	REMARKS	APPROVED BY

ASS'Y GROUP:		SIZE A3	INSTITUTE FOR PLASMA RESEARCH BHAT, GANDHINAGAR-382 428.	
ALL DIMENSIONS ARE IN 'mm' UNLESS OTHERWISE STATED				
SCALE	NTS	DATE	TITLE BACK PLATE & FW ASSY.	
DRAWN	SKP			
CHECKED	ATIK		REF DRG NO:	REV 00
APPROVED			DRG.NO	BKPA_IPR_01
			SHEET	1 OF 8

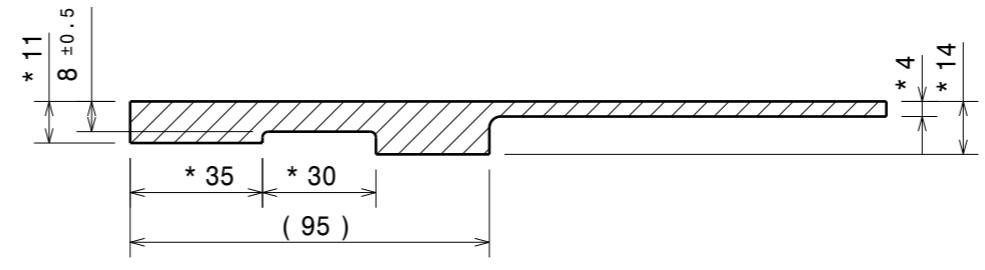
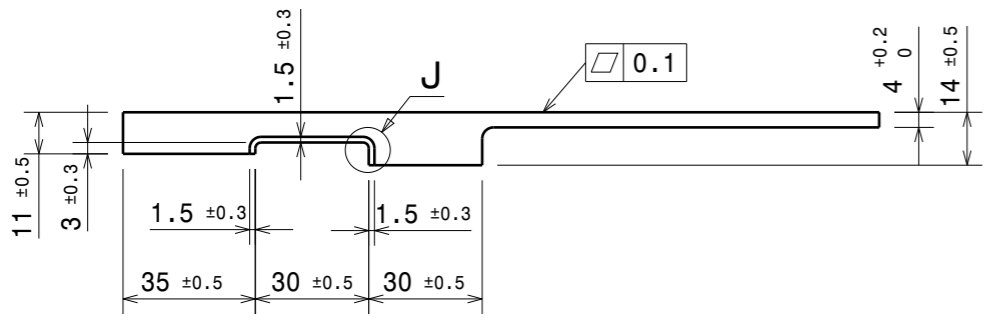

Section view H-H

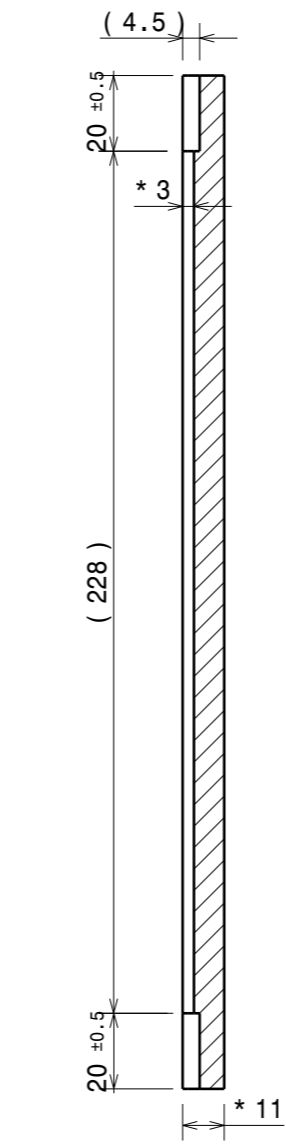
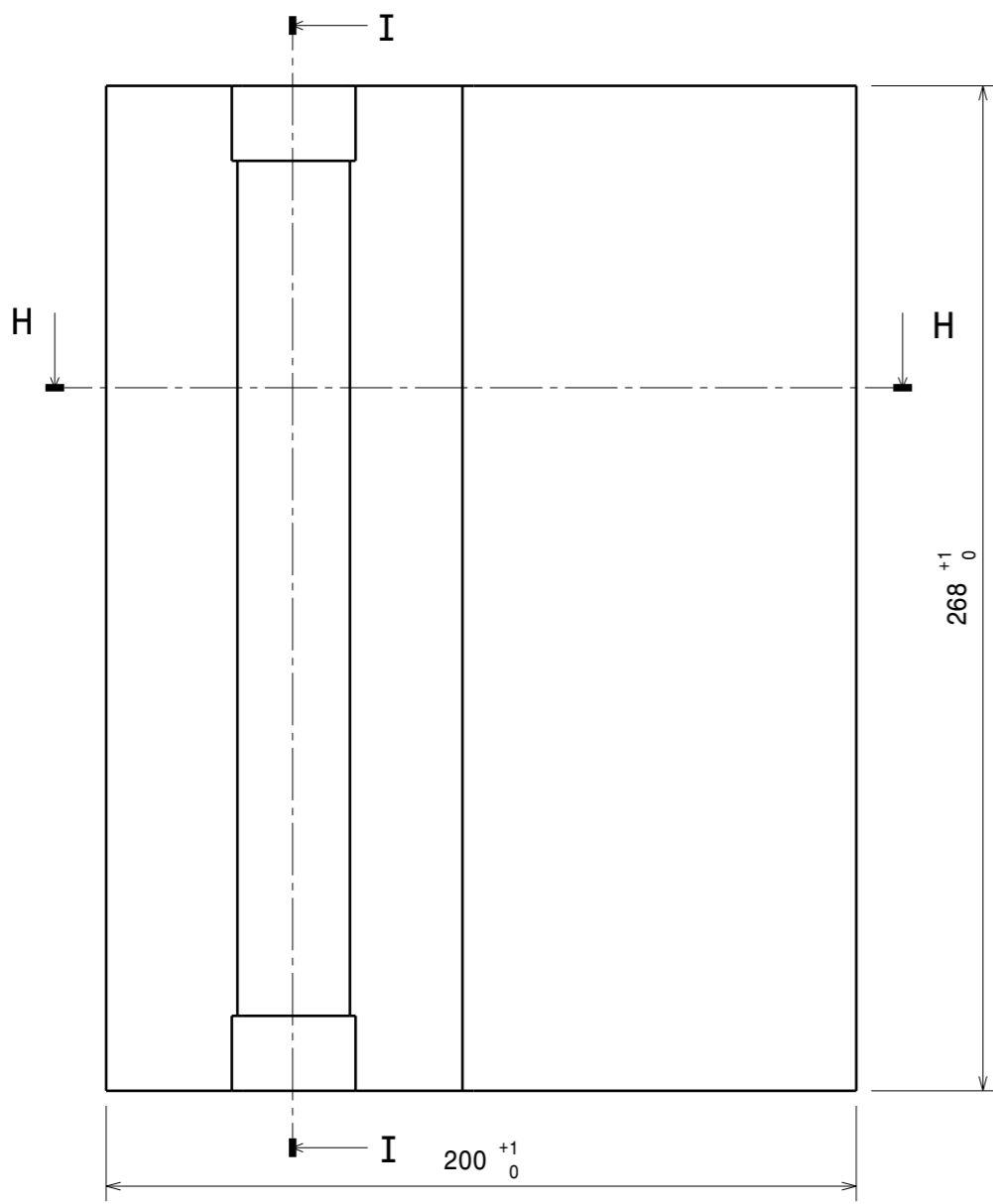

Section view I-I

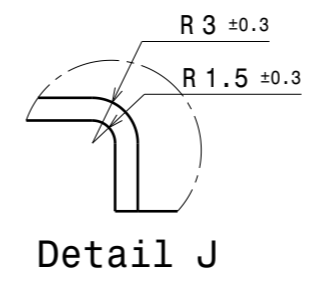

Detail J

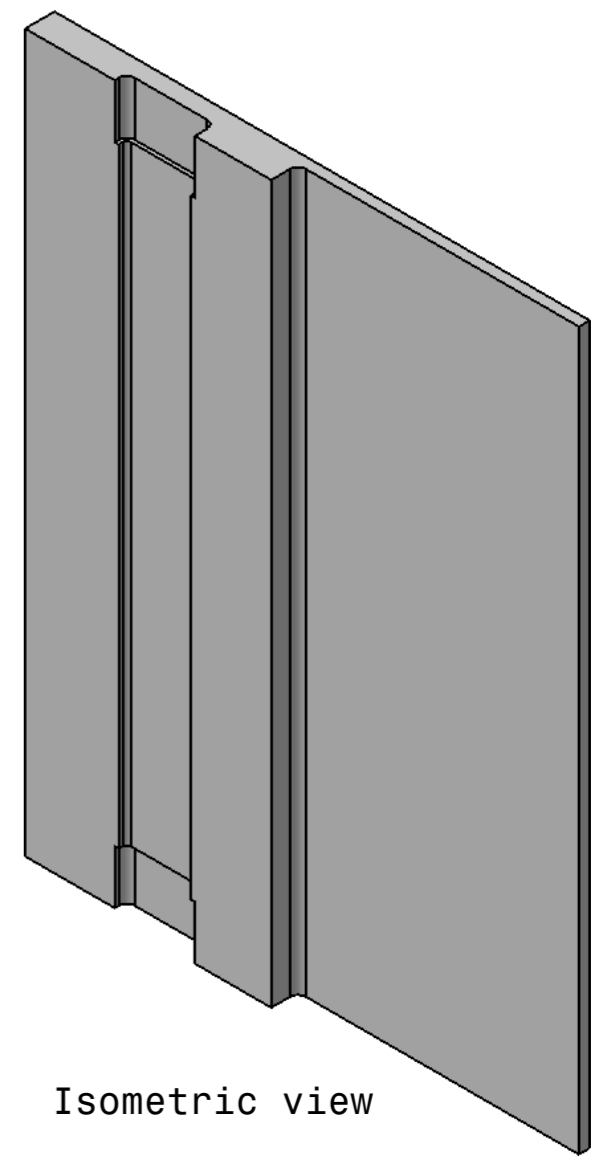

Isometric view

0.8

1. THE PLATES SHALL BE PRE-MACHINED TO ACHIEVE DIMENSIONAL ACCURACY.
2. REPAIR OF ANY DEFFECT BY WELDING IS NOT PERMITTED.
3. GENERAL TOLERANCE OF ± 0.3mm IF NOT MENTIONED.
4. DIMENSIONS GIVEN IN BRACKET (XX) REFER AS REFERENCE DIMENSION.
5. DIMENSIONS INDICATE BY * REFER AS REPEAT DIMENSIONS.

REVISION COLUMN						ASS'Y GROUP:	SIZE A3	INSTITUTE FOR PLASMA RESEARCH BHAT, GANDHINAGAR-382 428.		
REV	ZONE	DESCRIPTION	DATE	REMARKS	APPROVED BY	ALL DIMENSIONS ARE IN 'mm' UNLESS OTHERWISE STATED			TITLE	
						SCALE	NTS	DATE	SIDE PLATE	
						DRAWN	SKP		REF DRG NO: BKPA_IPR_01	
						CHECKED	ATIK		REV 00	
						APPROVED			DRG.NO	BKPA_IPR_01_1
									SHEET 2 OF 8	

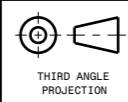

H G F E D C B A

0.8

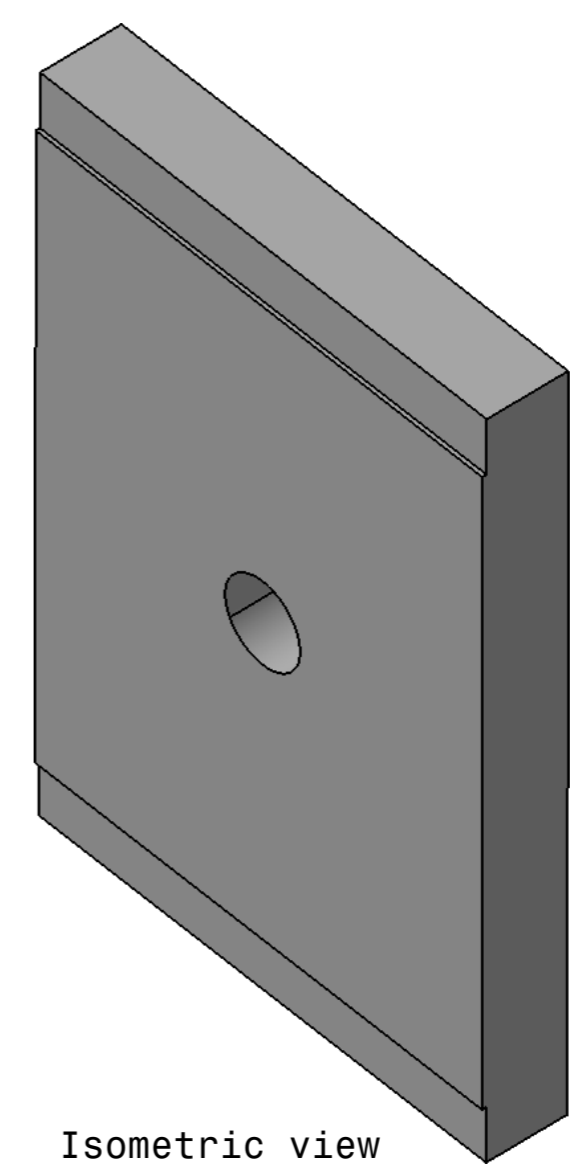
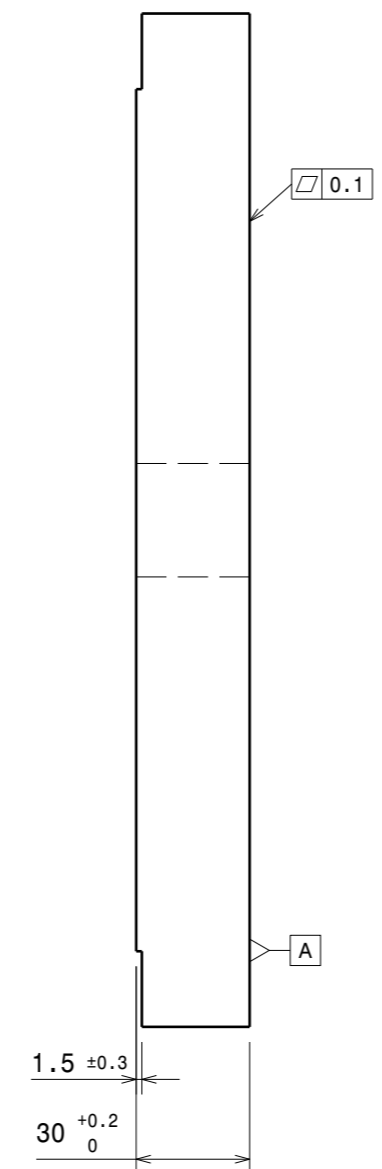
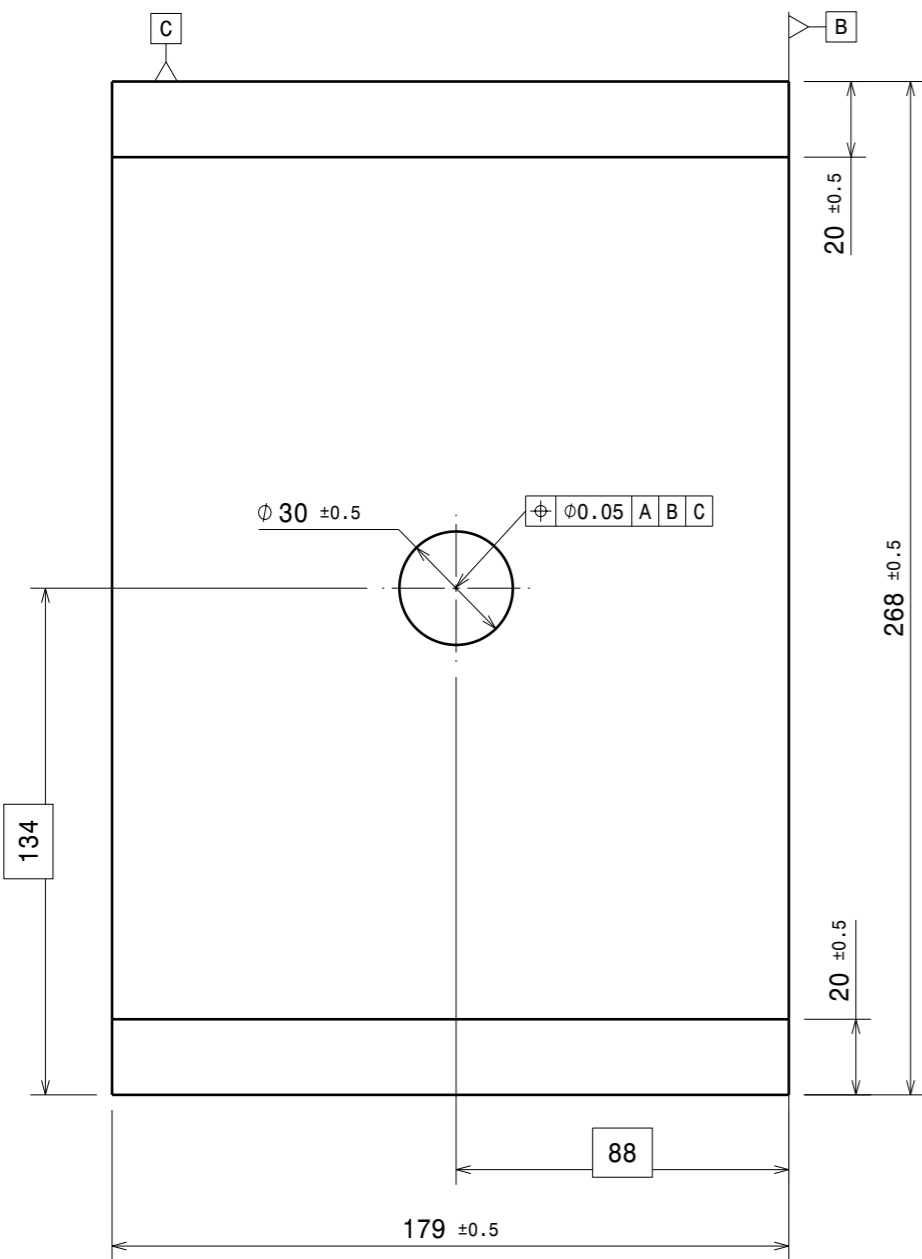

Isometric view

1. THE PLATES SHALL BE PRE-MACHINED TO ACHIEVE DIMENSIONAL ACCURACY.
2. REPAIR OF ANY DEFFECT BY WELDING IS NOT PERMITTED.
3. GENERAL TOLERANCE OF ± 0.3mm IF NOT MENTIONED.
4. DIMENSIONS GIVEN IN BRACKET (XX) REFER AS REFERENCE DIMENSION.
5. DIMENSIONS INDICATE BY * REFER AS REPEAT DIMENSIONS.

REVISION COLUMN						ASS'Y GROUP:	SIZE A3	INSTITUTE FOR PLASMA RESEARCH BHAT, GANDHINAGAR-382 428.			
REV	ZONE	DESCRIPTION	DATE	REMARKS	APPROVED BY	ALL DIMENSIONS ARE IN 'mm' UNLESS OTHERWISE STATED			TITLE INNER BACK PLATE		
						SCALE	NTS	DATE	REF DRG NO: BKPA_IPR_01		
						DRAWN	SKP		REV 00		
						CHECKED	ATIK		SHEET 3 OF 8		
						APPROVED			DRG.NO	BKPA_IPR_01_2	

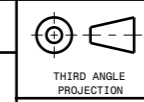

H G F E D C B A

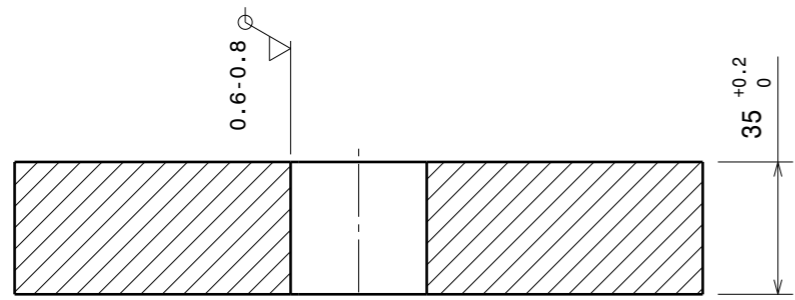

Section view C-C

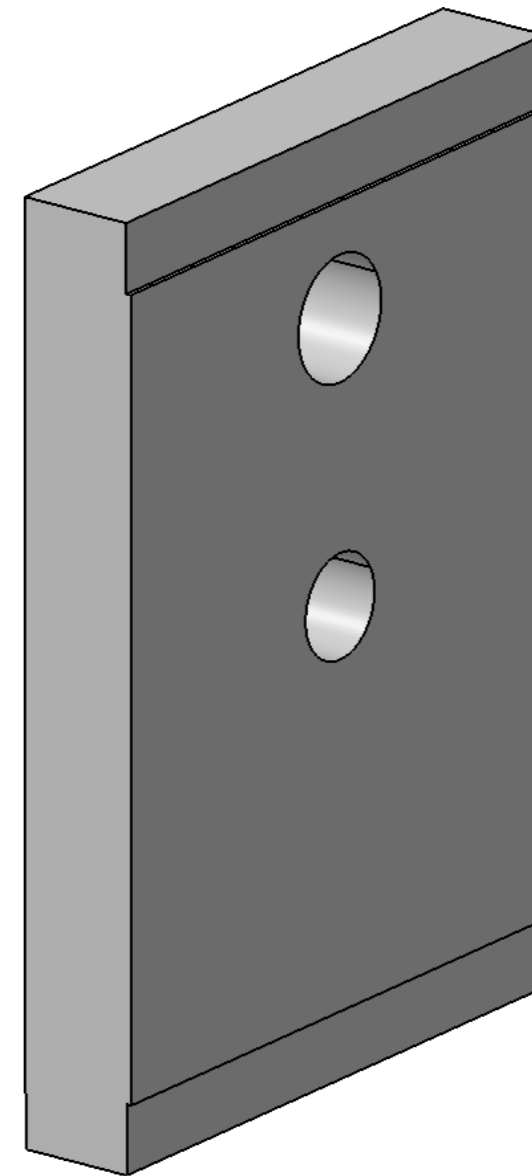
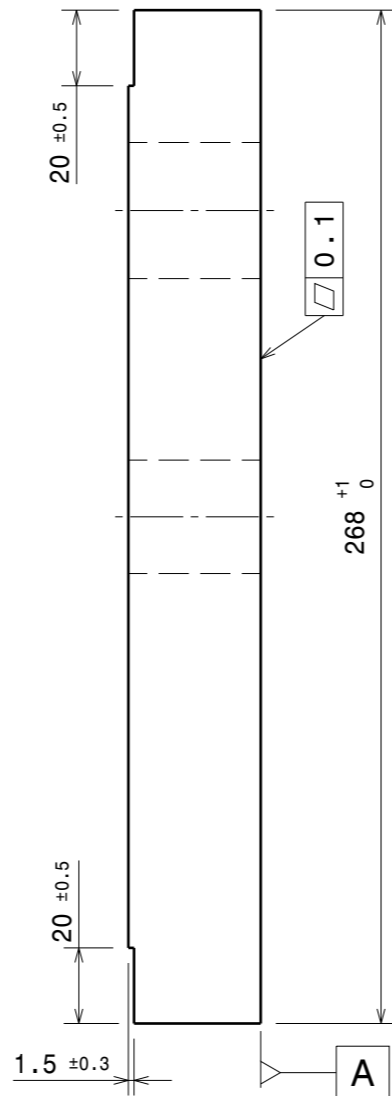
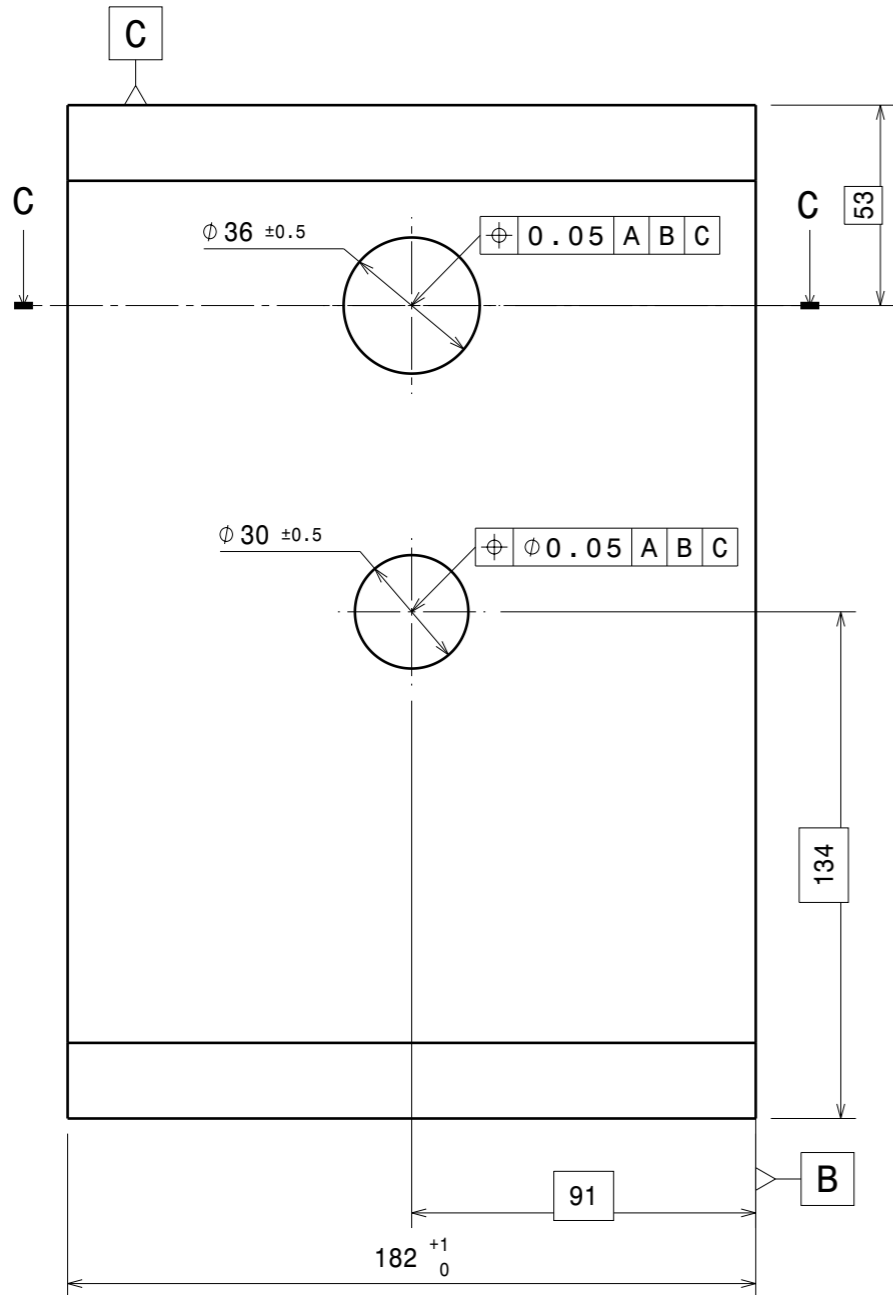

Isometric view

0.8

1. THE PLATES SHALL BE PRE-MACHINED TO ACHIEVE DIMENSIONAL ACCURACY.
2. REPAIR OF ANY DEFFECT BY WELDING IS NOT PERMITTED.
3. GENERAL TOLERANCE OF $\pm 0.3\text{mm}$ IF NOT MENTIONED.
4. DIMENSIONS GIVEN IN BRACKET (XX) REFER AS REFERENCE DIMENSION.
5. DIMENSIONS INDICATE BY * REFER AS REPEAT DIMENSIONS.

REVISION COLUMN						ASS'Y GROUP:	SIZE A3	INSTITUTE FOR PLASMA RESEARCH BHAT, GANDHINAGAR-382 428.			
REV	ZONE	DESCRIPTION	DATE	REMARKS	APPROVED BY	ALL DIMENSIONS ARE IN 'mm' UNLESS OTHERWISE STATED			TITLE		
						SCALE	NTS	DATE	THIRD ANGLE PROJECTION		
						DRAWN	SKP		OUTER BACK PLATE		
						CHECKED	ATIK		REF DRG NO: BKPA_IPR_01		REV 00
						APPROVED			DRG.NO	BKPA_IPR_01_3	SHEET 4 OF 8

H G F E D C B A

0.8

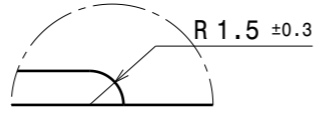
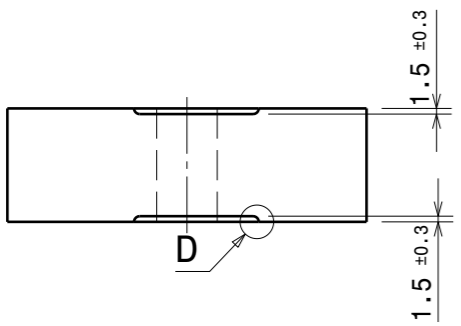

Detail D

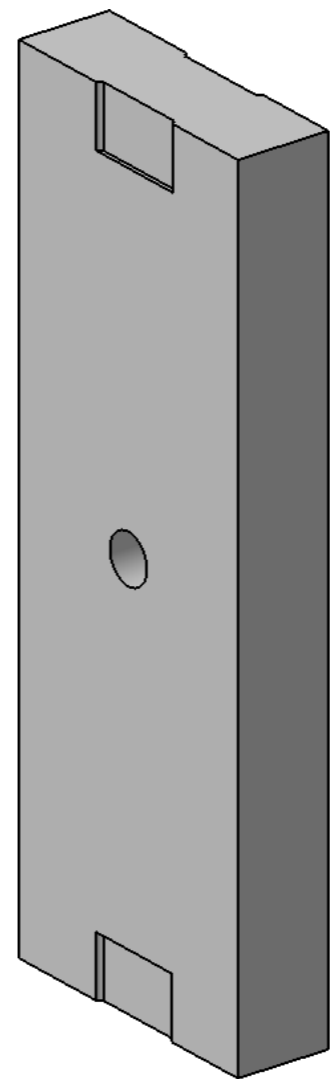

Isometric view

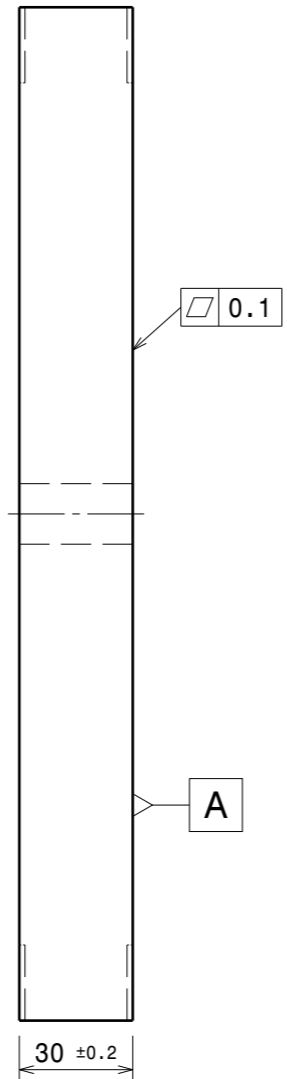
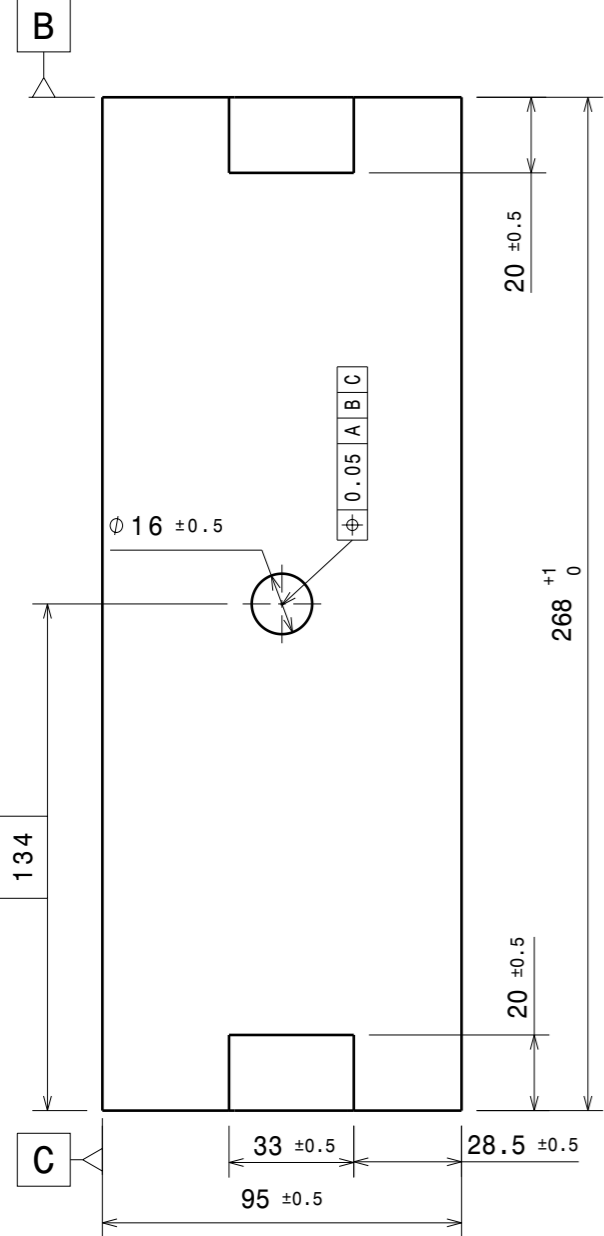

1. THE PLATES SHALL BE PRE-MACHINED TO ACHIEVE DIMENSIONAL ACCURACY.
2. REPAIR OF ANY DEFFECT BY WELDING IS NOT PERMITTED.
3. GENERAL TOLERANCE OF ± 0.3 mm IF NOT MENTIONED.
4. DIMENSIONS GIVEN IN BRACKET (XX) REFER AS REFERENCE DIMENSION.
5. DIMENSIONS INDICATE BY * REFER AS REPEAT DIMENSIONS.

REVISION COLUMN						ASS'Y GROUP:	SIZE A3	INSTITUTE FOR PLASMA RESEARCH BHAT, GANDHINAGAR-382 428.		
REV	ZONE	DESCRIPTION	DATE	REMARKS	APPROVED BY	ALL DIMENSIONS ARE IN 'mm' UNLESS OTHERWISE STATED			TITLE	
						SCALE	NTS	DATE	MID PLATE	
						DRAWN	SKP		REF DRG NO: BKPA_IPR_01	
						CHECKED	ATIK		REV 00	
						APPROVED			DRG.NO	BKPA_IPR_01_4
									SHEET 5 OF 8	

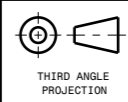

H G F E D C B A

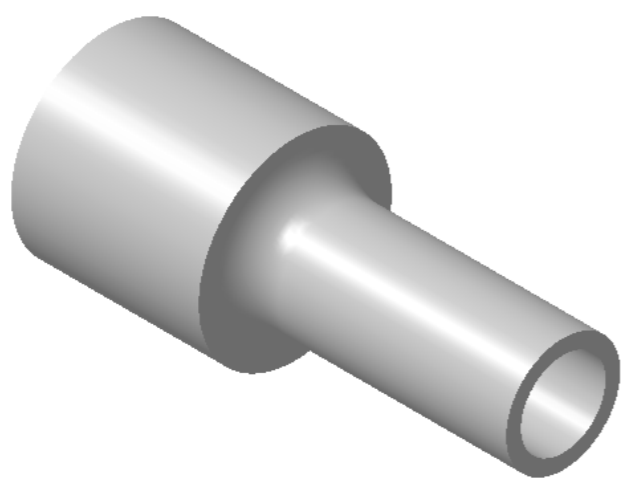
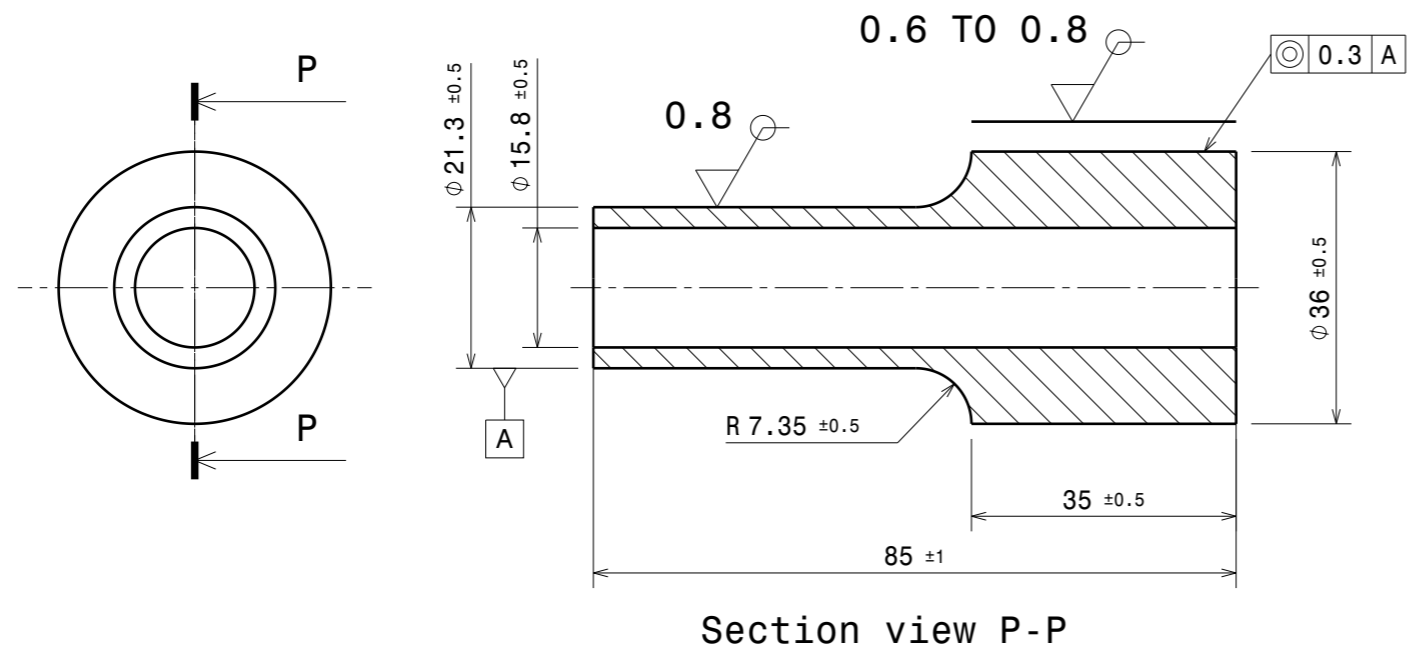

Isometric view

1. THE PLATES SHALL BE PRE-MACHINED TO ACHIEVE DIMENSIONAL ACCURACY.
2. REPAIR OF ANY DEFFECT BY WELDING IS NOT PERMITTED.
3. GENERAL TOLERANCE OF $\pm 0.3\text{mm}$ IF NOT MENTIONED.
4. DIMENSIONS GIVEN IN BRACKET (XX) REFER AS REFERENCE DIMENSION.
5. DIMENSIONS INDICATE BY * REFER AS REPEAT DIMENSIONS.

REVISION COLUMN						ASS'Y GROUP:	SIZE A3	INSTITUTE FOR PLASMA RESEARCH BHAT, GANDHINAGAR-382 428.			
REV	ZONE	DESCRIPTION	DATE	REMARKS	APPROVED BY	ALL DIMENSIONS ARE IN 'mm' UNLESS OTHERWISE STATED					
						SCALE	NTS	DATE	TITLE <div style="text-align: center; font-weight: bold; font-size: 1.2em;">PIPE</div>		
						DRAWN	SKP				
						CHECKED	ATIK		REF DRG NO: BKPA_IPR_01		
						APPROVED			DRG.NO BKPA_IPR_01_5		
									REV	00	
									SHEET	6 OF 8	

H G F E D C B A

0.8

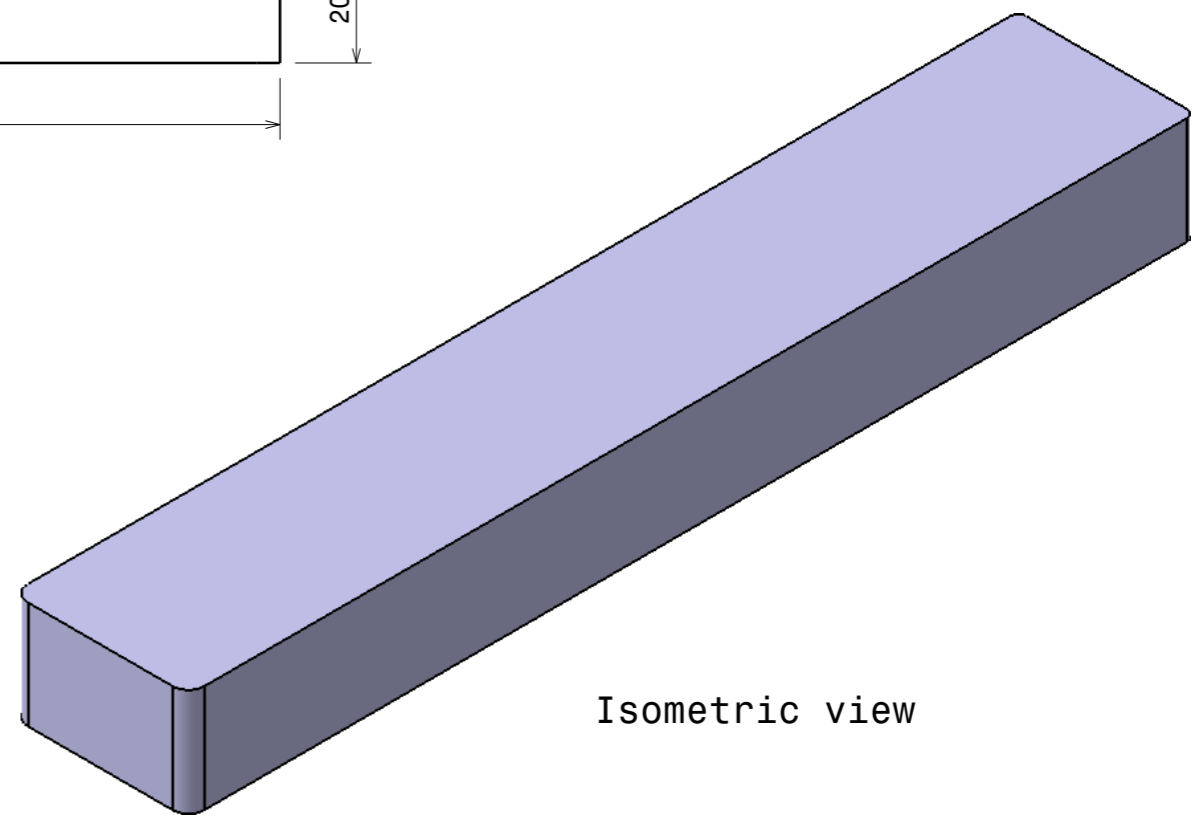
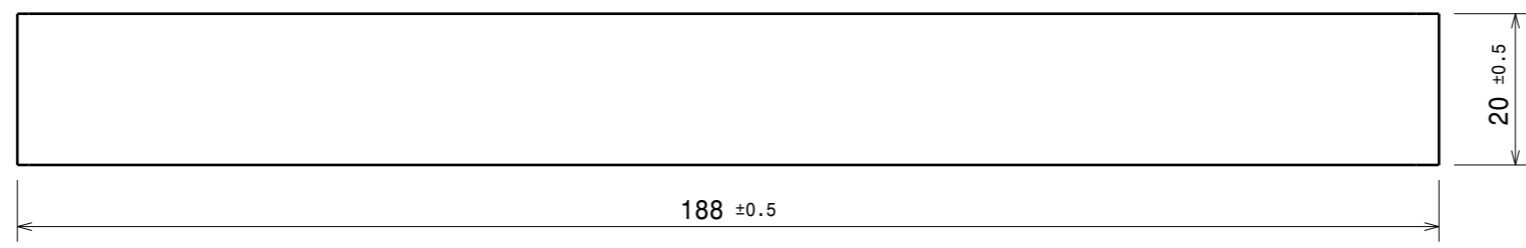
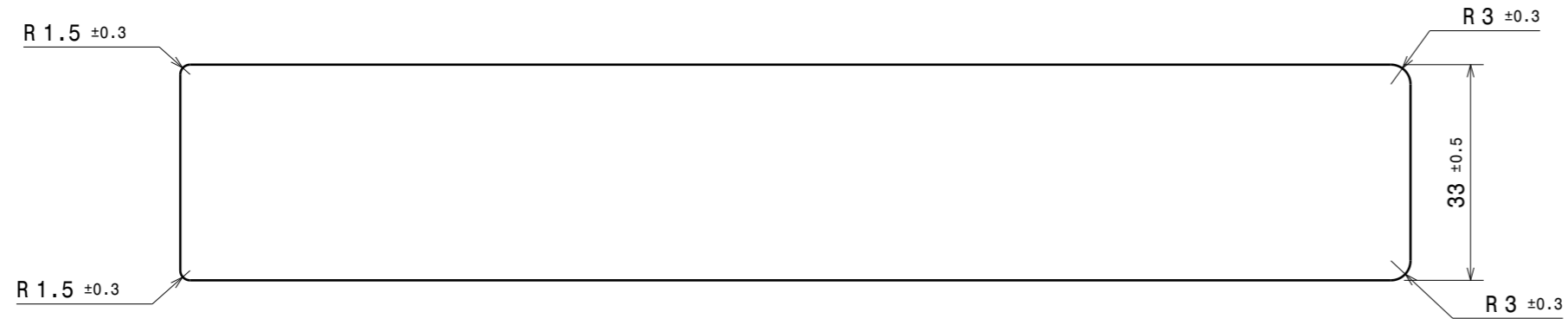

Isometric view

1. THE PLATES SHALL BE PRE-MACHINED TO ACHIEVE DIMENSIONAL ACCURACY.
2. REPAIR OF ANY DEFFECT BY WELDING IS NOT PERMITTED.
3. GENERAL TOLERANCE OF $\pm 0.3\text{mm}$ IF NOT MENTIONED.
4. DIMENSIONS GIVEN IN BRACKET (XX) REFER AS REFERENCE DIMENSION.
5. DIMENSIONS INDICATE BY * REFER AS REPEAT DIMENSIONS.

REVISION COLUMN						ASS'Y GROUP:	SIZE A3	INSTITUTE FOR PLASMA RESEARCH BHAT, GANDHINAGAR-382 428.		
REV	ZONE	DESCRIPTION	DATE	REMARKS	APPROVED BY	ALL DIMENSIONS ARE IN 'mm' UNLESS OTHERWISE STATED			TITLE COVER PLATE	
						SCALE	NTS	DATE	THIRD ANGLE PROJECTION	
						DRAWN	SKP			
						CHECKED	ATIK		REF DRG NO: BKPA_IPR_01	REV 00
						APPROVED			DRG.NO BKPA_IPR_01_6	SHEET 7 OF 8

H G F E D C B A

H G F E D C B A

0.8

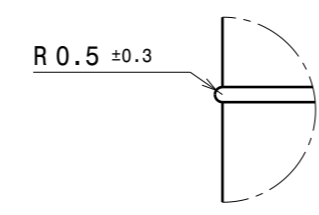
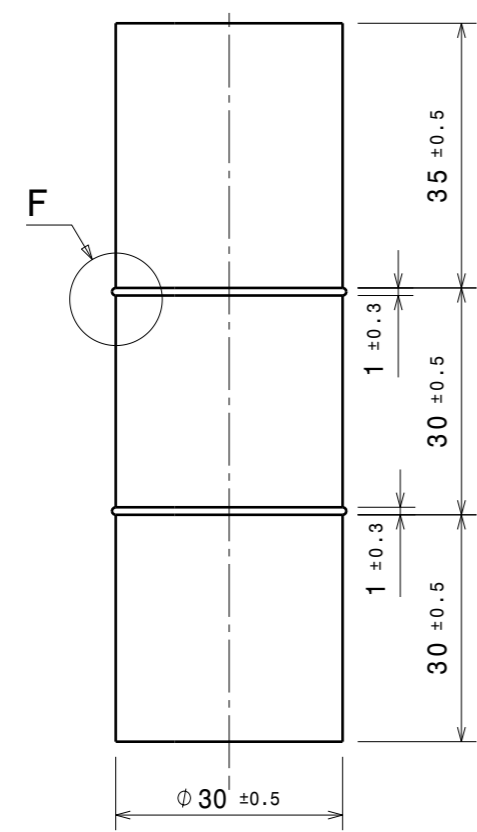
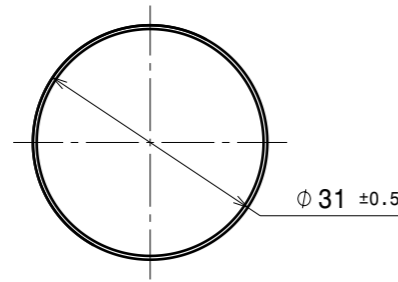

Detail F

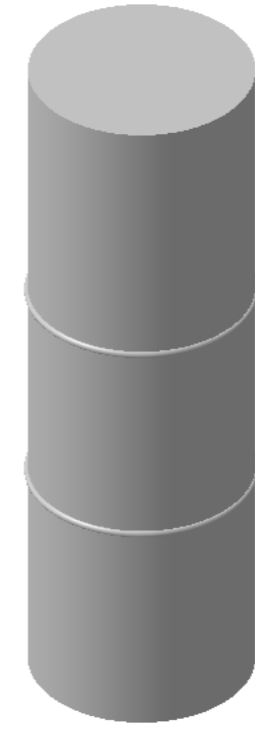

Isometric view

1. THE PLATES SHALL BE PRE-MACHINED TO ACHIEVE DIMENSIONAL ACCURACY.
2. REPAIR OF ANY DEFFECT BY WELDING IS NOT PERMITTED.
3. GENERAL TOLERANCE OF ± 0.3 mm IF NOT MENTIONED.
4. DIMENSIONS GIVEN IN BRACKET (XX) REFER AS REFERENCE DIMENSION.
5. DIMENSIONS INDICATE BY * REFER AS REPEAT DIMENSIONS.

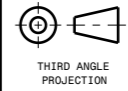
REVISION COLUMN						ASS'Y GROUP:	SIZE A3	INSTITUTE FOR PLASMA RESEARCH BHAT, GANDHINAGAR-382 428.			
REV	ZONE	DESCRIPTION	DATE	REMARKS	APPROVED BY	ALL DIMENSIONS ARE IN 'mm' UNLESS OTHERWISE STATED			TITLE STIFFNER PIN		
						SCALE	NTS	DATE			
						DRAWN	SKP		REF DRG NO: BKPA_IPR_01		
						CHECKED	ATIK		DRG.NO BKPA_IPR_01_7		REV 00
						APPROVED			SHEET 8 OF 8		

H G F E D C B A