

This file has been cleaned of potential threats.

To view the reconstructed contents, please SCROLL DOWN to next page.

INSTITUTE FOR PLASMA RESEARCH

An Aided institute of department of Atomic Energy, Govt. of India)
Near Indira Bridge, Bhat. DIST.GANDHINAGAR - 382 428 (INDIA)
PHONE :(079-2396 2000),FAX :91-079-23962277
Web : www.ipr.res.in

MINOR FABRICATION WORKS ENQUIRY

Office Copy

ENQUIRY NO :IPR/MFW/20-21/90

Date : 04-01-2021

Due Date : 20-01-2021 13:00 IST

Please send your offer in sealed envelope specifying Inquiry No, Date & Due Date, ALONG WITH your credentials for the following items:

Important Note:

Please note that e-mail quotations are not acceptable however you may send your queries (if any) to **asircar@ipr.res.in**

Please Ensure that your sealed quotation reaches this office not later than above mentioned due date and time.

Kindly go through the following document properly before Quoting which are available on the IPR web portal i.e., <http://www.ipr.res.in/documents/tenders.html/> attached here with.

1. Technical specification as enclosed.
2. Instruction to the bidders & terms and Condition (refer Form NO:**IPR-MFW-01-V1**)
3. Bidding format(refer Biddingformat MFW-Bid.pdf)

GST fro Goods and Services (IGST/CGST/SGST TAX BENEFITS): PLEASE REFER clause no:8 of Form No:**IPR-MFW-01-V1**

QUOTATION SHOULD BE ADDRESSED TO **AMIT SIRCAR** ONLY.

Sr.No.	Description	Quantity	Rate
1	Fabrication of circular U-bend test mock-up	1	No.

Free Issue Material

Sr.No.	Description	Quantity	Unit	Value
1	NA	0.00		0.00

Note : Please quote with complete technical details (Technical Compliance sheet and product data sheet)

Encl:As per attachment

Sd/-
AMIT SIRCAR
Scientific Officer-G

Technical specification

Fabrication of circular U-bend test mock-up

1. Introduction:

The Pb-Li MHD loop has been developed at IPR to perform the MHD studies in the test mock-ups with different flow configurations. The fabrication of U-bend MHD test mock up having circular flow cross-section (I.D. =52.48mm, O.D. = 60.3mm) has been planned. The test mock-up will be integrated with the Pb-Li MHD loop to perform the MHD experiments. The picture of the test mock-up is shown in **Fig.1**. The test mock-up will be equipped with the large number of potential pins (~72Nos.) and thermo-couple ports (32 Nos.) for wall electric potential and temperature measurements respectively. The reference drawing is given in **Annexure-I**.

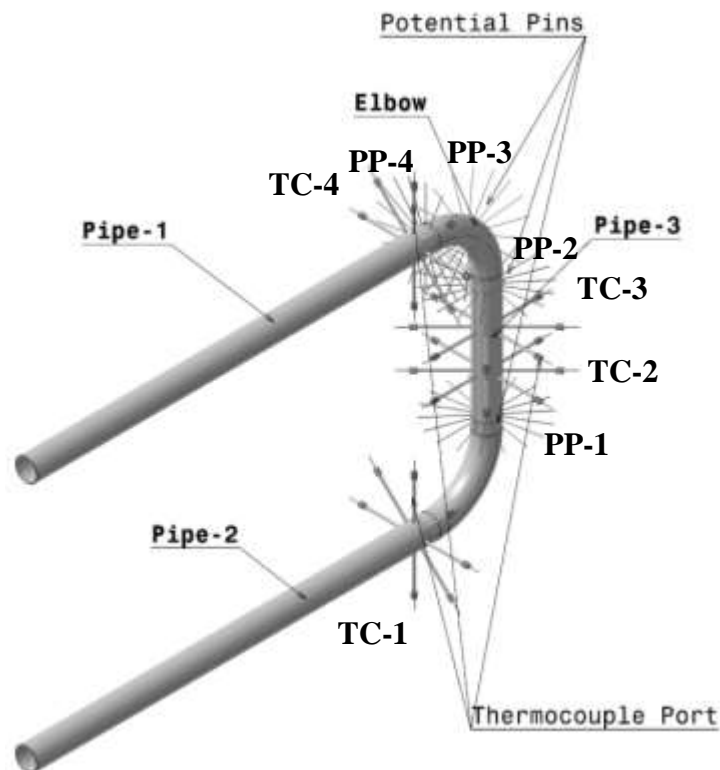

Fig.1. Picture of the test mock up. TC-1, TC-2, TC-3 & TC-4 are the cross-sectional locations of thermocouple ports. PP-1, PP -2, PP -3 & PP -4 are the cross-sectional location of potential pins.

2. Scope of the work:

This work involves procurement of material, fabrication of the test mock up, hydro test, pressure test and helium leak test of the test mockup. All the welding should be performed by qualified vendor as per standard codes. The test mockup will be fabricated along with the required diagnostics. The locations as well as numbers of the diagnostics and its welding strategies are given in **Annexure-I** and **Annexure-II**.

- 2(i). Vendor should study the engineering drawings of the test mock up given by IPR (Refer **Annexure-1**) and prepare detail fabrication drawings. Vendor may suggest any modifications in the drawings with justification. IPR will review those suggestions and may accept, if found suitable. Based on the IPR feedback, the vendor shall prepare the final fabrication drawing.
- 2(ii). Vendor shall not proceed for fabrication without IPR approval. The vendor shall fabricate the test mock up as per the approved fabrication drawings. The detail fabrication drawings based on the engineering drawing provided by the IPR should be prepared and submitted to IPR for approval prior to the test mock up fabrication.
- 2(iii). Vendor shall procure the required materials as per the required specifications (**Refer Sec.3**) and submit the material test certificate obtained from the government approved labs.
- 2(iv). Vendors shall follow the prescribed codes and standards for materials procurement, fabrication and testing of the test mock up (**Refer Sec. 5**).
- 2(v). Pre-dispatch inspection (PDI) will be performed by IPR representatives at vendor's site as per the tests described in **Section 8**.
- 2(vi). For PDI at vendor site, vendor shall write to IPR Purchase officer informing the status of fabrication of the test mock up and their readiness to perform the PDI, well in advance (preferably 1 week before).
- 2(vii). Vendor shall arrange all the required test facilities and instrumentation for the PDI at their site. (e.g. Necessary equipment for the helium leak test, hydro-test, electrical testing of potential pins etc.).
- 2(viii). All the PDI test results should confirm to the technical specifications mentioned in the purchase order. Based on the submission of PDI test results to IPR and its acceptance, dispatch clearance will be provided by Purchase Officer, IPR.
- 2(ix). Before shipment, vendors shall clean the Test mock-up properly, free from any moisture, water etc. and pack them as per the requirements mentioned in **section 11**.

- 2(x). After delivery of shipment at IPR, acceptance tests will be performed by IPR as per the details mentioned in **section 9**.
- 2(xi). The test mock-up will be accepted only after the successful completion of site acceptance tests at IPR.
- 2(xii). Vendor shall submit the final fabrication drawings (as built), material certificates and other test certificates along with the shipment.

3. Material:

The test mock up should be fabricated with the standard 2”pipe made of SS316L. For temperature measurement, standard 1/4" stainless steel pipe with the length of ~100mm will be welded on the test mock up at each temperature measuring location after making hole ($\Phi\sim 8\text{mm}$) on the test mock up as mentioned in **Annexure-II**. For the wall electric potential measurement, rods ($\Phi\sim 1.5\text{mm}$) made of SS316L will be used as mentioned in **Annexure-II**. All the required material (SS316L rods, and pipe etc.) should be procured by vendor and test reports should be submitted to IPR before starting of the fabrication.

4. Fabrication Requirement: The test mockup shall be fabricated as per the procedure given in **Annexure-II**.

5. Codes and standards:

The test mock up should be fabricated and tested as per the ASME standard.

6. Inspection Test and Reports: The procurement of material and fabrication work should start after receiving the approval from IPR.

7. Documentation: Following documents should be submitted

- a. Material test certificates
- b. Dimension Inspection report
- c. DP (Dye penetrant) and RT (Radio graphic) test report
- d. Hydro test report
- e. Helium leak test report

8. Acceptance test as Vendor site:

The test mock up, after completion of fabrication, will be tested at vendor’s site. IPR authorised representative will witness the test. Following test will be performed.

- a. Standard Dimensional checks: The test mock-up will be subjected to standard dimensional checks.
- b. Standard Pneumatic Test: The test mock-up will be held at the test pressure for minimum of 30 minutes. Vendor has to demonstrate no leakage at room temperature up

to 5bar pressure for nearly 30 minutes. In addition Helium leak test should also be performed.

c. Electrical testing of the potential pins

Note: - It should be noted that the vendor has to arrange all the test facilities at his site for the above-mentioned test.

9. Acceptance test as IPR: After delivery of the fabricated test mock up at IPR, visual inspection for any damage followed by Helium leak test will be carried out by IPR.

10. Deliverable: A test mockup with the attached diagnostics, fabrication drawings, documents mentioned in **Section-7**.

11. Delivery Period: The delivery shall be made within 8 weeks after placement of the purchase order and subsequent acceptance by the vendor. Item should be properly packed in a wooden box. The shipment shall be delivered to, The Stores In-Charge, IPR, Bhat, Gandhinagar 382 428 Gujarat, India.

ANNEXTURE-I (DRAWING of TEST MOCK UP)

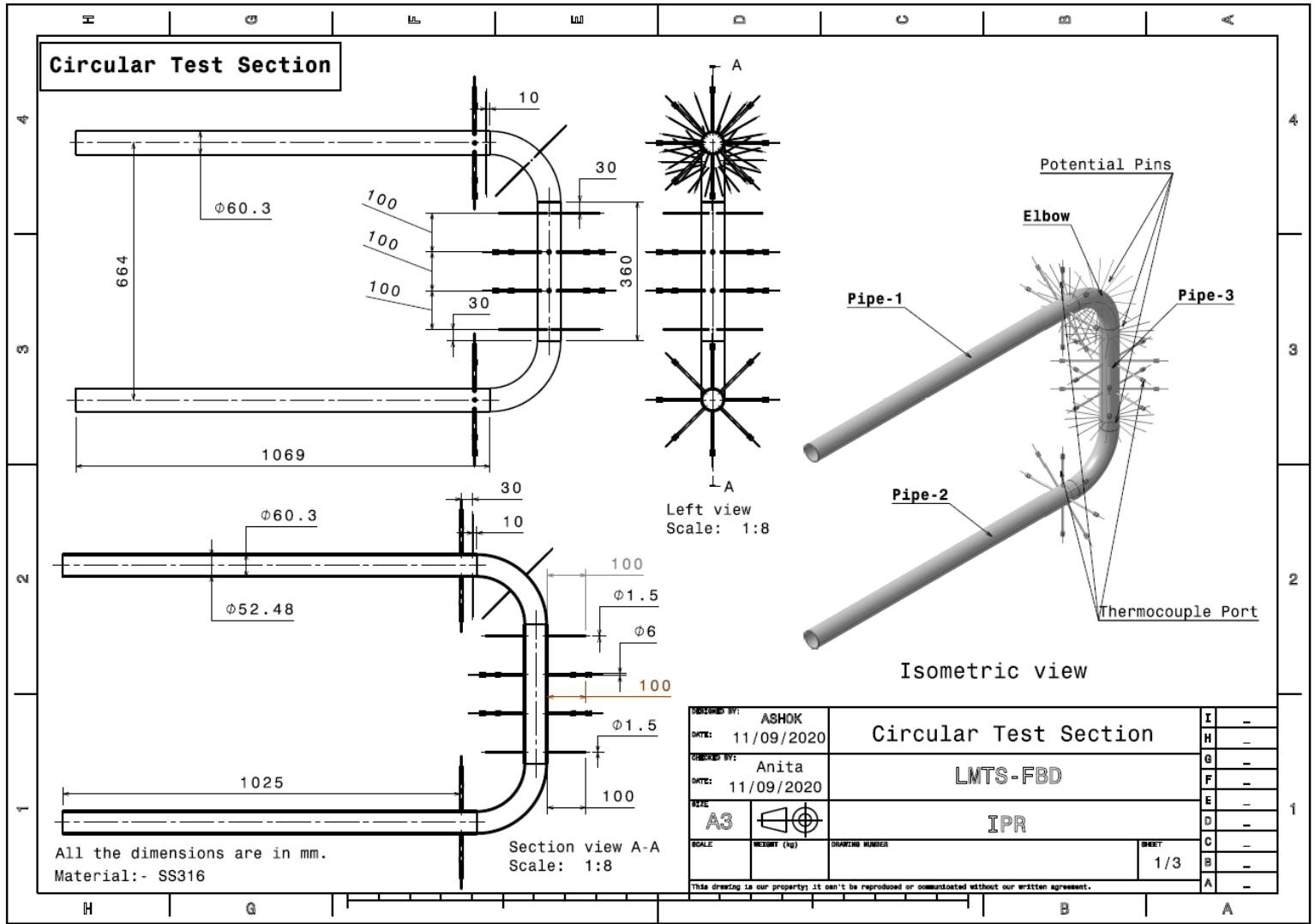

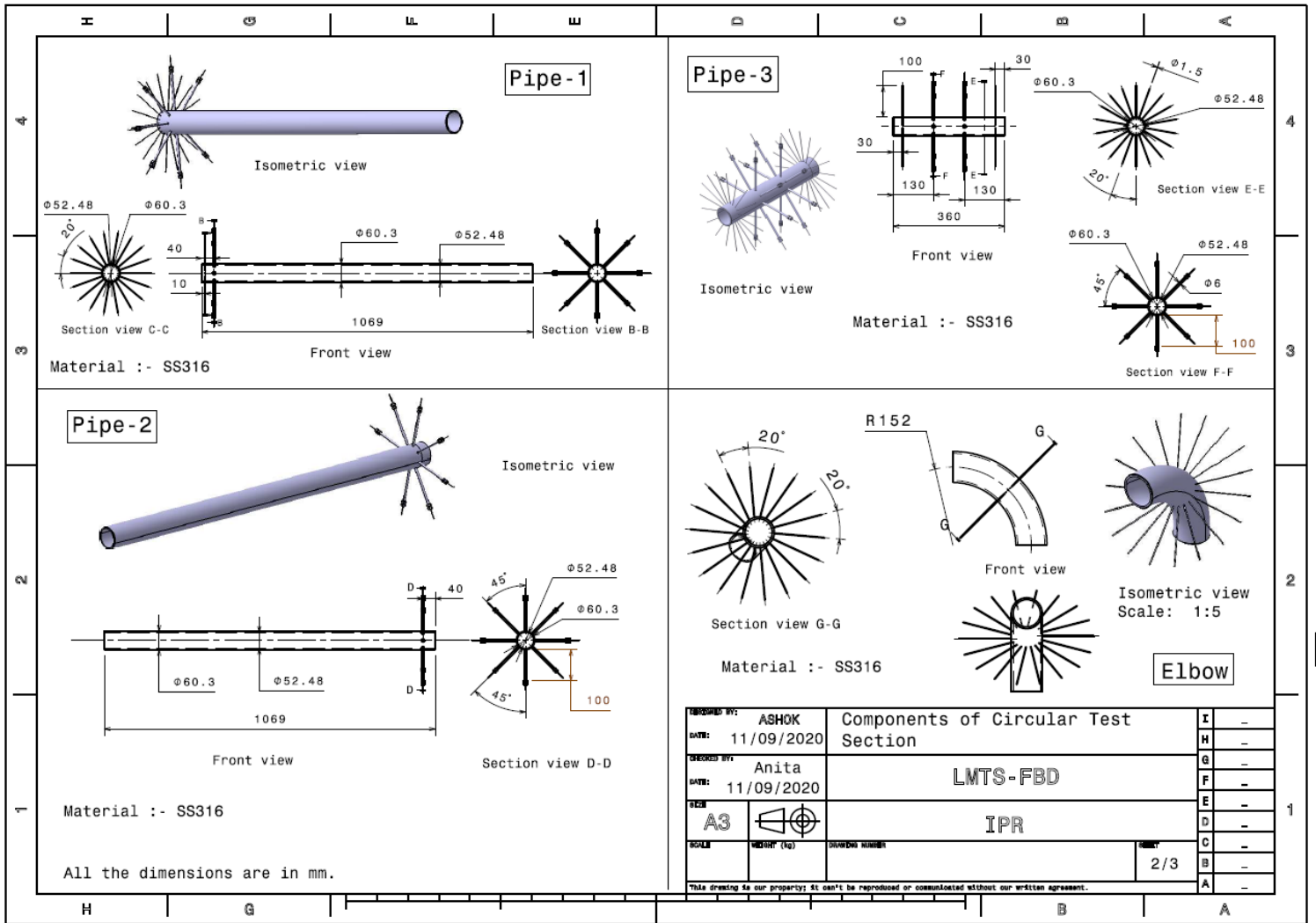

DESIGNED BY:	ASHOK	Components of Circular Test Section	I	-
DATE:	11/09/2020		H	-
CHECKED BY:	Anita	LMTS-FBD	G	-
DATE:	11/09/2020		F	-
SHEET	A3	IPR	E	-
SCALE	METRIC (kg)		D	-
			C	-
			B	-
			A	-
This drawing is our property; it can't be reproduced or communicated without our written agreement.				
				2/3

Part-1 Thermowell

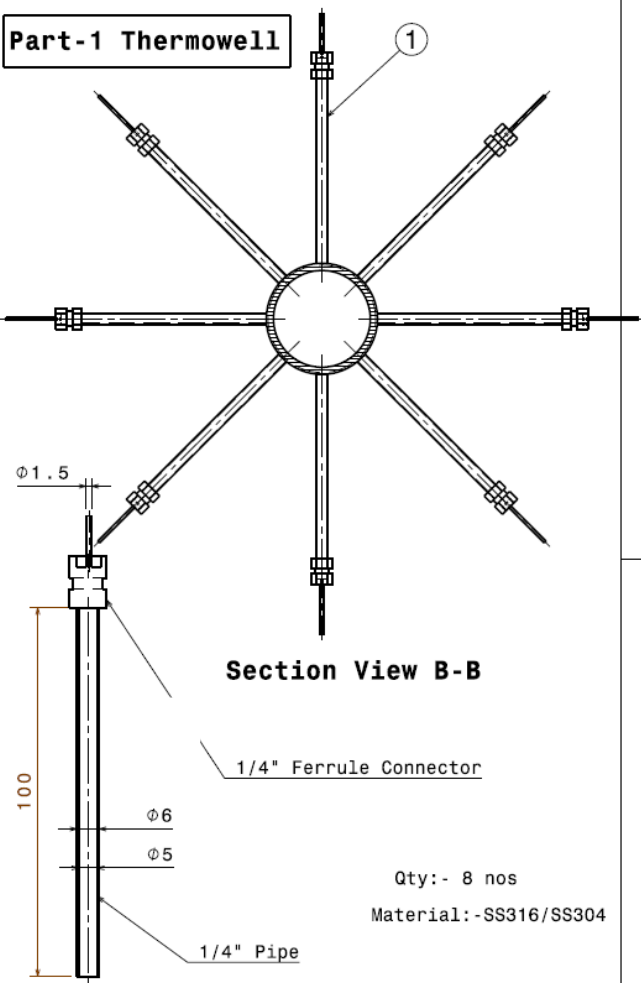

Section View B-B

1/4" Ferrule Connector

1/4" Pipe

Qty:- 8 nos

Material:-SS316/SS304

Part-2 Pins

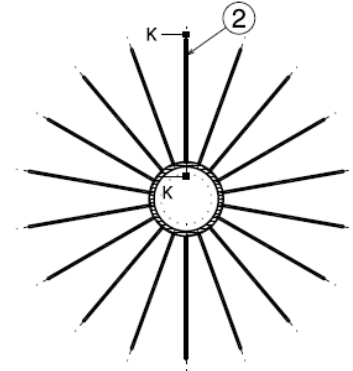
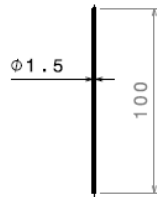

Section View C-C

Material- SS316/SS304

Qty:- 18 nos

- Note:- (1) Total pins are required for complete assembly
(18 x 4 = 72 nos)
- (2) Total thermowell are required for complete assembly
(8 x 4 = 32 nos)

DESIGNED BY:	ASHOK	Circular Test Section	I	-
DATE:	11/09/2020		H	-
DESIGNED BY:	Anita	LMTS-FBD	G	-
DATE:	11/09/2020		F	-
SIZE:	A3	IPR	E	-
SCALE:	1:1		D	-
WEIGHT (kg)		C	-	
DRAWING NUMBER		B	-	
		A	-	

This drawing is our property; it can't be reproduced or communicated without our written agreement.

ANNEXTURE-II (DRAWING for DIAGNOSTIC ARRANGEMENT)

1. **Potential Pin Welding Strategy:** For electric potential measurement, a stainless steel (SS316L) rod ($\Phi \sim 1.5\text{mm}$) of sufficient length ($\sim 100\text{mm}$) will be welded on the test mockup. On the outer side of the pipe, hole of $\Phi \sim 2.0\text{mm}$ for a depth of 1.5mm would be made; rod will be inserted and welded (TIG welding) from outside as shown in **Fig.1**.

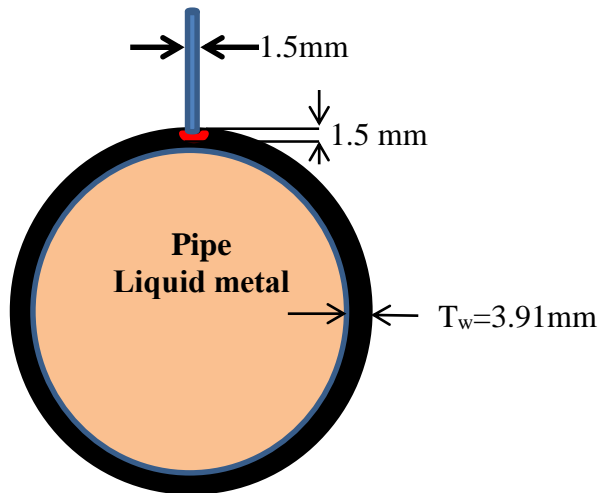
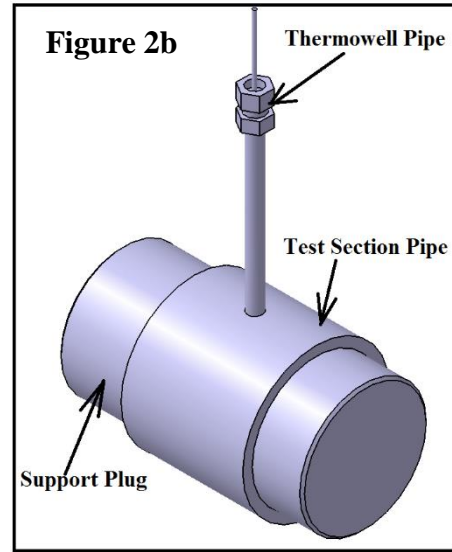
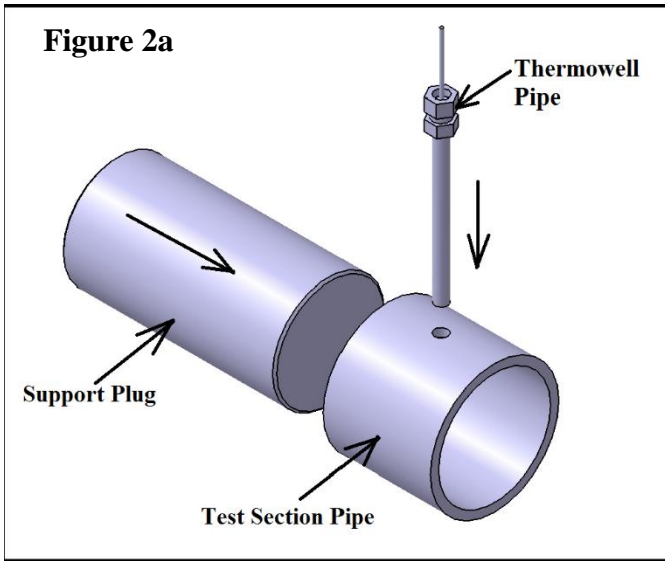

Fig.1 Schematic of welding of the potential pins on the pipe

2. **Welding Strategy of thermo well in the pipe of test mock-up:** Thermo-well will be used for insertion of thermocouples. Initially a hole will be made on the pipe of test mock up as shown in **Fig.2a**. One end of thermo-well tube (length $\sim 100\text{mm}$) will be grinded in curve form. Further a support plug will be inserted into the pipe of test mock-up to support the thermo-well tube. Thereafter grinded end of thermo-well tube will be inserted into drilled hole ($\Phi \sim 8\text{mm}$) and weld tag will be performed between the surface of pipe of the test mock-up and thermo-well tube as shown in **Fig.2b**.



Compliance sheet for Fabrication of circular U-bend test mock-up
(To be filled by Vendor)

Enquiry No: IPR/MFW/20-21/90

Due date: January 20, 2021

Sr. No.	IPR Requirement	Vendor's Specification	Deviation (If any)
1	Vendor should study the engineering drawings of the test mock up given by IPR (Refer Annexure-1) and prepare detail fabrication drawings. Vendor may suggest any modifications in the drawings with justification. IPR will review those suggestions and may accept, if found suitable. Based on the IPR feedback, the vendor shall prepare the final fabrication drawing.		
2.	Vendor shall not proceed for fabrication without IPR approval. The vendor shall fabricate the test mock up as per the approved fabrication drawings. The detail fabrication drawings based on the engineering drawing provided by the IPR should be prepared and submitted to IPR for approval prior to the test mock up fabrication.		
3.	Vendor shall procure the required materials as per the required specifications (Refer Sec.3) and submit the material test certificate obtained from the		

	government approved labs.		
4.	Vendors shall follow the prescribed codes and standards for materials procurement, fabrication and testing of the test mock up (Refer Sec. 5).		
5.	Pre-dispatch inspection (PDI) will be performed by IPR representatives at vendor's site as per the tests described in Section 8 .		
6.	For PDI at vendor site, vendor shall write to IPR Purchase officer informing the status of fabrication of the test mock up and their readiness to perform the PDI, well in advance (preferably 1 week before).		
7.	Vendor shall arrange all the required test facilities and instrumentation for the PDI at their site. (e.g. Necessary equipment for the helium leak test, hydro-test, electrical testing of potential pins etc.).		
8	All the PDI test results should confirm to the technical specifications mentioned in the purchase order. Based on the submission of PDI test results to IPR and its acceptance, dispatch clearance will be provided by Purchase Officer, IPR.		

9	Before shipment, vendors shall clean the Test mock-up properly, free from any moisture, water etc. and pack them as per the requirements mentioned in section 11 .		
10	After delivery of shipment at IPR, acceptance tests will be performed by IPR as per the details mentioned in section 9 .		
11	The test mock-up will be accepted only after the successful completion of site acceptance tests at IPR.		
12	Vendor shall submit the final fabrication drawings (as built), material certificates and other test certificates along with the shipment.		

(This need to be printed in Bidders letter head)

1. Please quote with complete technical details.
2. Quotation should be submitted with below (Quotation format) else IPR shall not consider the offer submitted by the vendor for further evaluation

NAME OF PARTY : _____

ENQUIRY NO: _____ DUE ON: _____

QUOTATION No. & DATE : _____

Currency of Quotation: **Indian Rupees**

Sr. No.	Item Description	Quantity	Rate (Basic)	Packaging & forwarding (P&F)	Applicable GST	Rate (incl P&F and GST)	Value
		a	b	c	d	e= b+c+d	f = a x e
1							
2							
3							
4							

Sr. No.	PARTICULAR	Remarks
I.	Ex-works / FOR Destination	
II.	Freight	
III.	Insurance	
IV.	Delivery Period	
V.	Payment (IPR terms will apply)	
VI.	Guarantee / Warrantee	
VII.	Validity Period	
VIII.	Discount (if any)	
IX.	Remarks	

Note: Enclose technical compliance sheet with your quotation
Fill in the all applicable details.

Place:

Authority Signatory

Date:

Company Seal

Bidder should submit the copy of GSTIN / ARN Certificate along with the offer



INSTRUCTIONS TO BIDDERS AND TERMS AND CONDITIONS

1. The Quotation and any order resulting from this enquiry shall be governed by our Conditions of Contract/Purchase Order and supplier quoting this enquiry shall be deemed to have read and understood the same in toto.
 2. Where counter terms and conditions have been offered by the Tenderer, the same shall not be deemed to have been accepted by IPR unless our specific written acceptance thereof is obtained.
 3. **Quotation:** Quotation should be submitted in the prescribed QUOTATION FORMAT attached with this Enquiry and the same should be submitted to the Purchase Officer, IPR in a sealed envelope superscribing the same with our enquiry No., date, due date and brief description of item on or before the due date. Late/delayed/incomplete/unsigned quotations will not be considered. Envelopes received without Enquiry number, date, due date and brief description of item may be rejected. The quoted prices should be firm for a period of 90 days from due date for placing order. IPR is not bound to accept lowest rate/s. IPR reserves the right to place on one or more parties. The scope of supply includes insurance by the Contractor/Supplier.
 4. **Specifications:** Material should be offered strictly confirming to our specifications/drawings. Deviation, if any, should be clearly indicated by the supplier in their quotation. The Tenderer should also indicate the Make/Type number of the materials offered and catalogues, technical literature and samples, wherever necessary should accompany the quotation. Clarification/s on drawings should be obtained before submitting quotation.
 5. **Terms of Prices:** Quotation should be submitted on door delivery basis without extra charge wherever possible. For quotations on Ex-Works, Ex-godown basis the approximate packing and forwarding charges should be indicated by the supplier. In the case of local suppliers, the material is to be delivered at our stores free of charge.
 - 5.1 In respect of tenders on Ex-works basis, in case the tenderer has not mentioned in the offer packing, forwarding and transportation charges for safe delivery up to Purchaser's site, 2% of the price quoted towards packing (in respect of both local and outstation firms), 1% of the basic price quoted towards safe delivery charges in respect of local tenderer and 3% of the basic price quoted towards safe delivery charges in respect of outstation firm will be added for comparison of offers on safe door delivery at Purchaser's site.
 - 5.2 Prices are required to be quoted according to the units indicated in the tender form/Enquiry. When Quotations are given in terms of units other than those specified in the tender form, relationship between the two sets of units must be furnished
 6. Tender should be free from Correction and Erasures. Corrections, if any, must be attested. All amounts shall be indicated both in words as well as in figures. Where there is difference between amounts quoted in words and figures, amount quoted in words shall prevail. Unsigned quotations will summarily be rejected. If there is a discrepancy between the unit price and total price, unit price shall prevail.
 7. IPR shall be under no obligation to accept the lowest or any tender and reserves the right of acceptance of the whole or any part of the tender or portion of the quantity offered and the tenderers shall supply the same at the rate quoted.
 8. **Goods & Services Tax (GST):** The details of Taxes/GST and other levies legally leviable and intended to be claimed should be clearly indicated in the tender. Where this is not done, no claim on these accounts would be admissible later.
 - a) **GST for Goods (IGST/CGST/SGST TAX BENEFITS):**

IPR is entitled to avail tax benefit as per the following notifications issued by Ministry of Finance, Department of Revenue, Government of India:
(1) No: 47/2017-INTEGRATED TAX (RATE) DATED 14/11/17 for IGST
(2) No: 45/2017-CENTRAL TAX (RATE) DATED 14/11/17 for CGST

And,

IPR is entitled to avail tax benefit as per the following notifications issued by Finance Department, Government of Gujarat:
(1) No. 45/2017-STATE TAX (RATE) DATED 15/11/17 for SGST

As per above notifications IPR will bear only 5% IGST for procurement of goods from outside Gujarat & 2.5% CGST and 2.5% SGST (total 5%) for procurement of goods within Gujarat. Vendors are required to charge tax as per these notifications while quoting/supplying the goods. Deviations, (if any) should be clearly mentioned in the quotation/offer.
- Please specify the HSN codes while quoting.**
- b) **GST for Services:**

As applicable. **Specify the SAC codes wherever services are involved.**
9. **Earnest Money Deposit (EMD):** Tenderer should furnish EMD if asked for by the Purchaser.
10. **Delivery Date:** Delivery period is essence of the Contract. Supplier must indicate the firm delivery date by which the materials will be dispatched/delivered by them from the date of our order. Delivery period shall be clearly indicated against each item separately.



प्लाज्मा अनुसंधान संस्थान
(भट, इन्दिरा पुल के पास, गांधीनगर 382428 - , गुजरात) भारत
Institute for Plasma Research

Bhat, Near Indira Bridge, Gandhinagar – 382428, Gujarat (INDIA)

Phone: +91-79-23962021 to 23962028 ; Fax: +91-79-23962277 Website: www.ipr.res.in



11. **Price/ Purchase Preference:** Purchase/Price preference to industries will be given as per the policy of the Government of India in force at the time of evaluation provided their offer is in compliance with the conditions of the policy.
12. **Liquidated Damages:** The successful Vendor/Bidder should pay liquidated damages @ ½% (half percent) of the total contract/order value for the delay of each week in the scheduled date of completion of the work envisaged in the Contract/Purchase Order subject to a maximum of 5% (Five percent) of the total Contract/Order value.
13. **Inspection:** Materials on its arrival at IPR will be inspected by our Engineer/Stores Officer, and his decision in the matter will be final. However, where the items are required to be inspected at the Suppliers Premises, Supplier has to give advance notice to the Purchase regarding readiness of the material to enable Purchase/Stores section to depute his representative for inspection.
14. **Payment:** Payment will be arranged for accepted materials only within 30 days from the date of receipt of materials at IPR and bills in our accounts section, completed in all respects.
15. No correspondence will be entertained within 30 days from the date of receipt of material and bills, whichever is later.
16. **Guarantee:** The Stores offered should be guaranteed for a minimum period of twelve months, from that date of acceptance, against defective materials, design, workmanship, operation or manufacture. For defects noticed and communicated during the Guarantee period, replacement/rectification should be arranged free of cost within a reasonable period of such notifications. In case where our specifications call for a guarantee period more than 12 months specifically, then such a period shall apply.
17. **Performance Bank Guarantee:** If demanded by IPR, the successful bidder will have to furnish Performance Bank Guarantee for 10% of the order value (basic price) from a Nationalised/Scheduled Bank/State Bank of India, valid throughout the Guarantee/Warranty period. The scheduled banks approved by IPR are Axis Bank, HDFC Bank, ICICI Bank and IDBI Bank. Bank Guarantees submitted other than from banks approved by IPR will not be accepted.
18. **Security Deposit:** If demanded the successful Bidder will have to furnish to the Purchaser an interest free security deposit for 10% (Ten percent) of the order value in the form of Bank Guarantee of an equivalent amount from a nationalized/ scheduled Bank/State Bank of India within 15 days from the date of LOI/Purchase order and the said Guarantee should be valid till the goods are accepted by IPR. The scheduled banks approved by IPR are Axis Bank, HDFC Bank, ICICI Bank and IDBI Bank. Bank Guarantees submitted other than from banks approved by IPR will not be accepted. The Security deposit shall be forfeited in case the selected Bidder does not start the work within the time limit specified or fail to complete the work within the stipulated delivery period or fail to comply with any of the terms and conditions in the purchase order/contract. On successful completion of scope of work and its acceptance by IPR, supplier should send a letter to the Purchase Officer to return the original BG.
19. The Contractor/Supplier shall at all times indemnify the purchase against all claims which may be made in respect of the stores for infringement of any right protected by Patent Registration of design or Trade Mark and shall take all risk of accidents or damage, which may cause failure of supply from whatever cause arising and the entire responsibility for sufficiency of all means used by him for the fulfilment of the contract.
20. **Free Issue Material (FIM):** Successful tenderer will have to arrange insurance showing beneficiary as “Institute for Plasma Research” at their risk and cost towards adequate security for the materials/property provided/issued by the Purchaser as Free Issue Material for the due execution of the contract.
21. The Director, IPR reserves the right to accept or reject any quotations fully or partly or to cancel the enquiry without assigning any reason.
22. **Jurisdiction:** The contract shall be governed by the Laws of India for the time being in force. The Courts of Gandhinagar only shall have jurisdiction to deal with and decide any legal or dispute arising out of this Contract/Purchase Order.