

This file has been cleaned of potential threats.

To view the reconstructed contents, please SCROLL DOWN to next page.

# INSTITUTE FOR PLASMA RESEARCH

An Aided institute of department of Atomic Energy, Govt. of India)  
Near Indira Bridge, Bhat. DIST.GANDHINAGAR - 382 428 (INDIA)  
PHONE :(079-2396 2000),FAX :91-079-23962277  
Web : www.ipr.res.in

## MINOR FABRICATION WORKS ENQUIRY

Office Copy

ENQUIRY NO :IPR/MFW/20-21/88

Date : 03-12-2020

**Due Date : 16-12-2020 13:00 IST**

Please send your offer in sealed envelope specifying Inquiry No, Date & Due Date, ALONG WITH your credentials for the following items:

Important Note:

Please note that e-mail quotations are not acceptable however you may send your queries (if any) to **ranjana@ipr.res.in**

Please Ensure that your sealed quotation reaches this office not later than above mentioned due date and time.

Kindly go through the following document properly before Quoting which are available on the IPR web portal i.e., <http://www.ipr.res.in/documents/tenders.html/> attached here with.

1. Technical specification as enclosed.
2. Instruction to the bidders & terms and Condition (refer Form NO:**IPR-MFW-01-V1**)
3. Bidding format(refer Biddingformat MFW-Bid.pdf)

GST fro Goods and Services (IGST/CGST/SGST TAX BENEFITS): PLEASE REFER clause no:8 of Form No:**IPR-MFW-01-V1**

QUOTATION SHOULD BE ADDRESSED TO **RANJANA GANGRADEY** ONLY.

| Sr.No. | Description   | Quantity | Rate |
|--------|---|----------|------|
| 1      | Fabrication, testing and supply of vacuum chamber with copper plate as per the drawings | 1        | No.  |

### Free Issue Material

| Sr.No. | Description | Quantity | Unit | Value |
|--------|-------------|----------|------|-------|
|--------|-------------|----------|------|-------|

Note : Please quote with complete technical details (Technical Compliance sheet and product data sheet)

Encl:As per attachment

Sd/-  
RANJANA GANGRADEY  
Scientific Officer-G

# Specification/Tender Document for “Fabrication, testing and supply of Vacuum chamber with copper plate”

## 1. Introduction:

The tender for the “Fabrication, testing and supply of Vacuum chamber with copper plate” is mainly aimed for the fabrication of SS 304 vacuum chamber with TIG welding and suitable manufacturing process as per the drawings provided by IPR. This vacuum chamber involves SS 304 Vacuum chamber, top part of chamber made up of SS 304 and mounting stand made up of mild steel (powder coated). Top part of chamber includes mounting of dome shaped copper plate using supports as per the drawings provided by IPR.

Cleaning of material should be thoroughly done before any welding process. Buffing should be done on the outer surface of the chambers and electro-polishing should be done on the inner surfaces of the chambers. Proper brazing using high content silver should be done on the copper pipe brazed on the top part of chamber. Brazing should not have any unfilled space. Final acceptance will be given after the verification of the components as per IPR’s requirement.

### A. Scope of Supply:

1. Vacuum chamber with top part, ISO 500 F blank flange with lifting handles.
2. All the flanges and ports should be covered including necessary bolts and washers, O-rings, CF-flange copper gaskets, Blank CF flanges, 40KF blank with O-ring, centre ring and clamp.
3. Complete assembled system should be supplied with steel tube, cooling tube and copper plate and other components as per the drawings.
4. MS powder coated mounting stand for the chamber.

**Note:** A list of supply must be submitted by the vendor before dispatch/delivery.

### B. Testing:

Testing of this vacuum chamber with complete assembly is required to be done by the vendor before supply and test report should be submitted to IPR before delivery. In the testing, following work need to be done:

1. **Leak testing:** Leak testing of the complete assembly in the vacuum mode using MSLD leak detector. Acceptable local leak rate is  $< 1 \times 10^{-9}$  mbar-l/s and global leak rate is  $< 5 \times 10^{-9}$  mbar-litre/sec.

### Note:

- O-ring (Viton/Nitrile) to be used should be in single-piece.

### C. Scope of work

- Fabrication, testing and supply of Vacuum chamber with copper plate
- Testing of the system as per the specifications and section B.

## 2. Specifications/Compliance

| Particulars  | Specification/Requirements  | Vendor's response             |
|--|---|-------------------------------|
| Fabrication of following components.                 | Vacuum chamber and it's all components as per the drawing   |                               |
| Working temperature                                  | Room Temperature  |                               |
| Material   | SS 304, G-10 , Mild steel and copper  |                               |
| Dimensions   | As per drawings   |                               |
| Testing of the assembly                              | Testing as per the specifications. During leak test, acceptable local leak rate is $< 1 \times 10^{-9}$ mbar-l/s and global leak rate is $< 5 \times 10^{-9}$ mbar-litre/sec. | Please mention the leak rate. |
| Brazing/welding requirements                         | Brazing should be done with high purity copper rod or silver brazing  |                               |
| Buffing and Electropolishing on chamber and top part | <ul style="list-style-type: none"> <li>• Buffing -outside</li> <li>• Electro-polishing-inside</li> </ul>  |                               |

### Note:

1. Vendor will have to fill the table with the details and also accept the same. This Compliance sheet has to be submitted along with the offer.
2. IPR can check the composition of material used in the fabrication of components before and during fabrication if necessary.

## 1. Drawings

| S. No. | Component name   | Material       | Drawing reference |
|--------|--|----------------|-------------------|
| 1.     | Assembly of Vacuum shaped Dome                                   | As per drawing | Sheet_1           |
| 2.     | Cross-section of Vacuum shaped Dome                              | As per drawing | Sheet_2           |
| 3.     | Vacuum shape dome and blank flange                               | As per drawing | Sheet_3           |
| 4.     | Steel tube, G-10 stud, G-10 nut, G-10 bush and washer            | As per drawing | Sheet_4           |
| 5.     | Mounting stand, stud and base support for stand and copper plate | As per drawing | Sheet_5           |
| 6.     | Top part of dome and cooling tube                                | As per drawing | Sheet_6           |

## 2. Delivery:

Within 3 (three) months after the purchase order/work order date.

### **3. Inspection at vendor's site:**

If required, IPR representative may verify the below mentioned specification of the components before delivery. After fabrication vendor will have to intimate IPR regarding the fabrication status.

1. Leak testing of vacuum chamber with copper plate
2. A list of supply must be submitted by the vendor before dispatch/delivery.

**Note:** If IPR's representative will not visit the vendor's site for inspection, vendor must submit test report of the final fabricated components. Based on the review of the report, delivery of the components will be done to IPR.

### **4. Acceptance:**

Final acceptance will be given after the testing of fabricated Vacuum chamber with copper plate at IPR's site. Testing will be done as per the specifications.

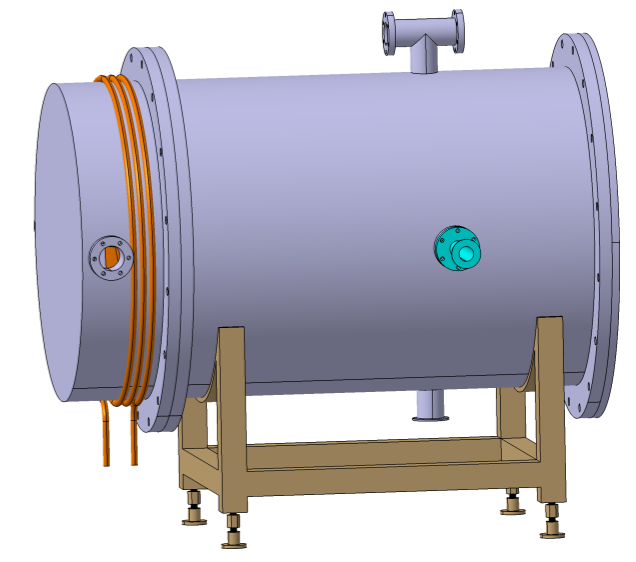
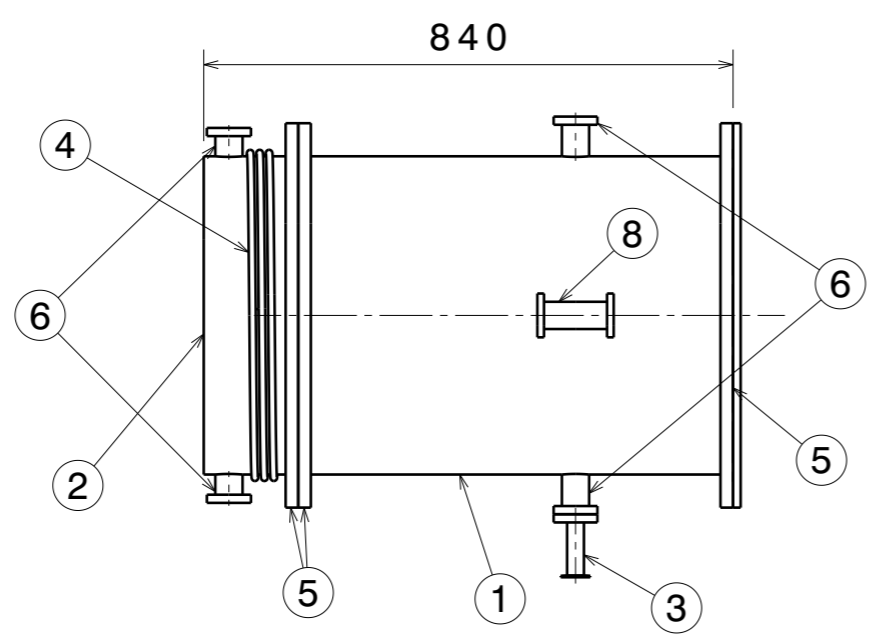
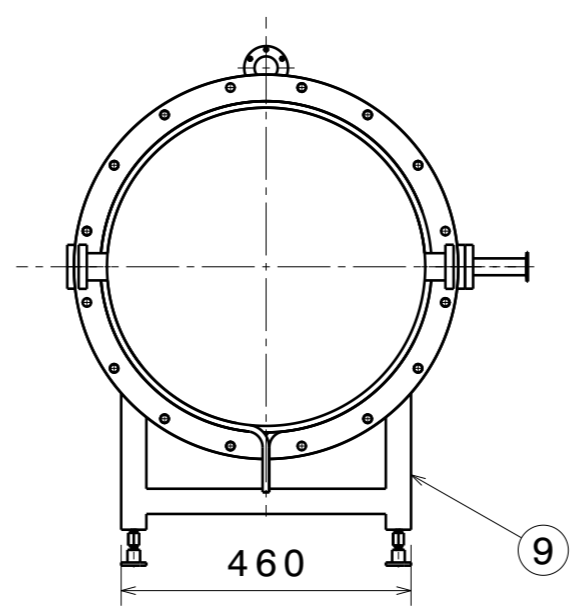
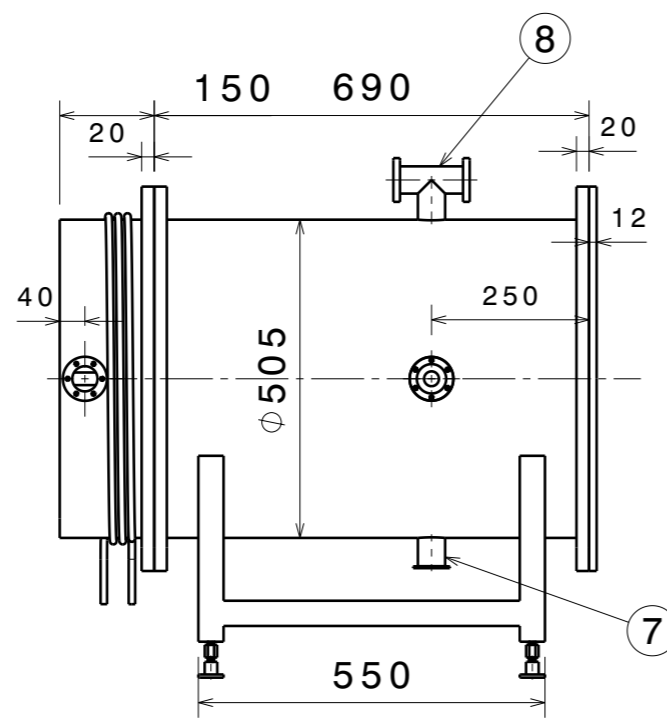
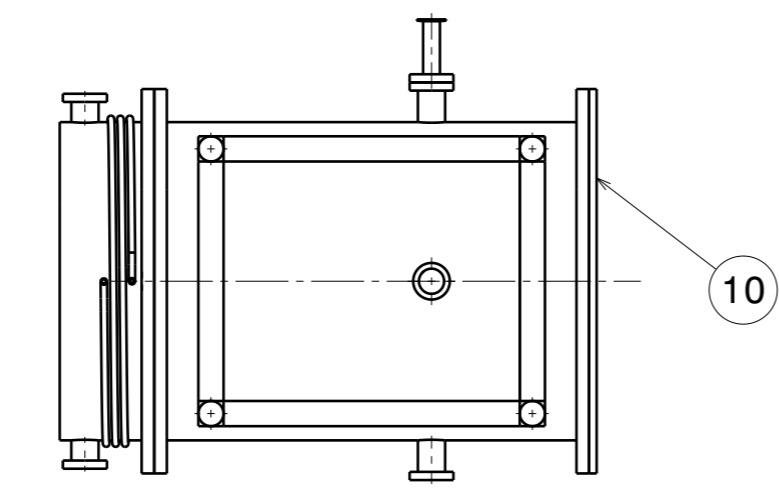
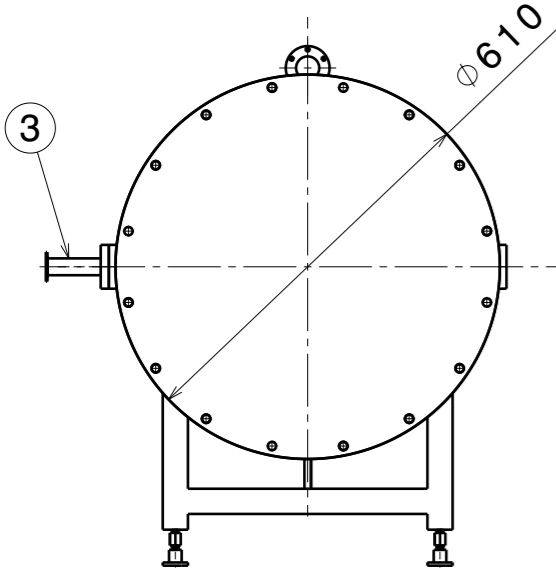

| COMP NO. | COMPONENT NAME      | MATERIAL   | QTY |
|----------|---------------------|------------|-----|
| 1        | VACUUME SHAPED DOME | SS304      | 1   |
| 2        | TOP PART OF DOME    | SS304      | 1   |
| 3        | STEEL TUBE          | SS304      | 1   |
| 4        | COOLING TUBE        | COPPER     | 1   |
| 5        | 500 F FLANGE        | SS304      | 3   |
| 6        | 40 CF PORT          | SS304      | 4   |
| 7        | 40 KF PORT          | SS304      | 1   |
| 8        | 40 CF TEE TUBE PORT | SS304      | 1   |
| 9        | MOUNTING STAND      | Mild Steel | 1   |
| 10       | 500 F BLANK FLANGE  | Mild Steel | 1   |

|                         |                                 |
|-------------------------|---------------------------------|
| DESIGNED BY:<br>ranjana | INSTITUTE FOR PLASMA RESEARCH   |
| DATE:<br>18-09-2020     |                                 |
| CHECKED BY:<br>XXX      | ASSEMBLY OF VACUUME SHAPED DOME |
| DATE:<br>XXX            |                                 |
| SIZE:<br>A3             | DRAWING NUMBER<br>1             |
| SCALE                   |                                 |
| WEIGHT (kg)<br>119.32   | SHEET<br>1/6                    |

ALL DIMETIONS ARE IN MM

This drawing is our property; it can't be reproduced or communicated without our written agreement.

|   |   |
|---|---|
| I | - |
| H | - |
| G | - |
| F | - |
| E | - |
| D | - |
| C | - |
| B | - |
| A | - |

H G F E D C B A

4

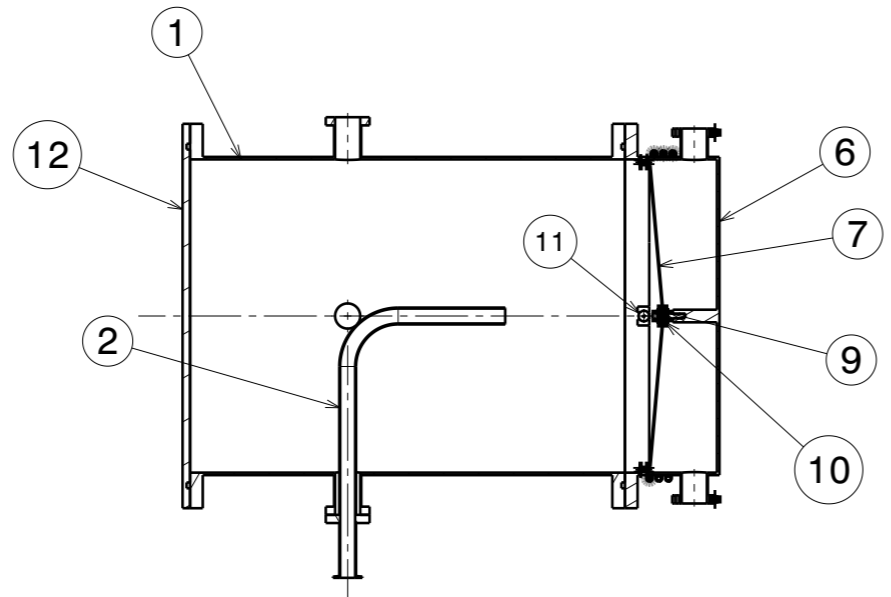

Section view Y-Y

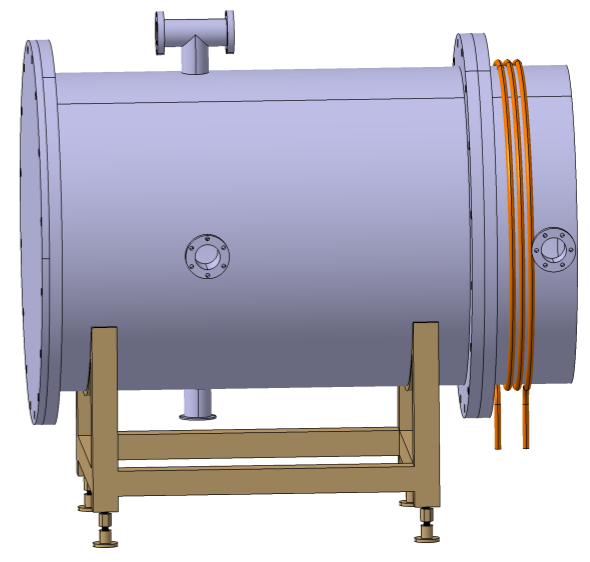

4

3

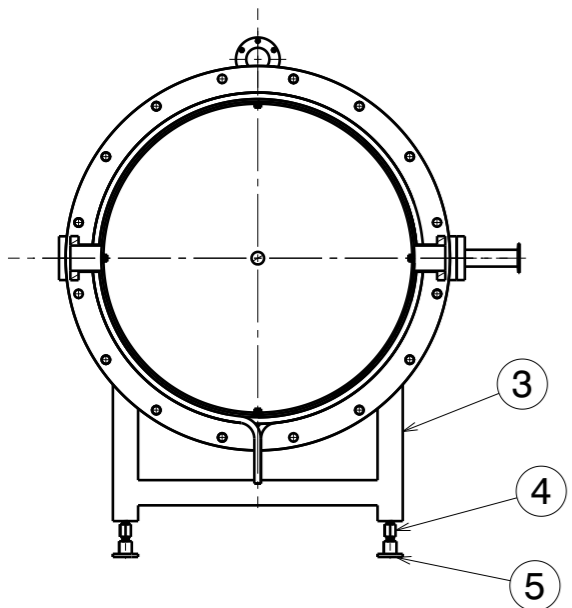

Section view Z-Z

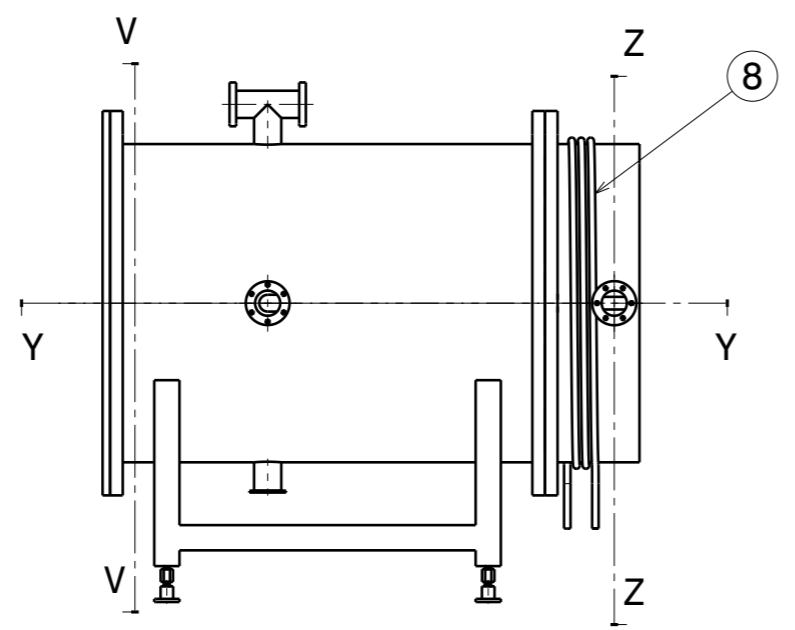

Section view V-V

3

| COMP NO. | COMPONENT NAME     | MATERIAL   | QTY. |
|----------|--------------------|------------|------|
| 1        | VACUUME SHAPE DOME | SS304      | 1    |
| 2        | STEEL TUBE         | SS304      | 1    |
| 3        | MOUNTING STAND     | Mild Steel | 1    |
| 4        | STUD               | SS304      | 1    |
| 5        | BASE FOR STAND     | SS304      | 1    |
| 6        | TOP PART OF DOME   | SS304      | 1    |
| 7        | COPPER PLATE       | COPPER     | 1    |
| 8        | COOLING TUBE       | COPPER     | 1    |
| 9        | G10 STUD           | SS304      | 1    |
| 10       | G10 NUT            | G10        | 2    |
| 11       | G10 BUSH           | G10        | 4    |
| 12       | 500 F BLANK FLANGE | Mild Steel | 1    |

2

2

1

|   |   |                             |   |   |
|---|---|-----------------------------|---|---|
| DESIGNED BY:<br>ranjana   | <b>INSTITUTE FOR PLASMA RESEARCH</b>      |                             | I | - |
| DATE:<br>18-09-2020   |   |                             | H | - |
| CHECKED BY:<br>XXX  | <b>CROSS SECTION OF VACUUM SHAPE DOME</b> |                             | G | - |
| DATE:<br>XXX  |   |                             | F | - |
| SIZE:<br><b>A3</b>  | WEIGHT (kg):<br><b>119.32</b>             | DRAWING NUMBER:<br><b>2</b> | E | - |
| SCALE:  | SHEET:<br><b>2/6</b>                      |                             | D | - |
| This drawing is our property; it can't be reproduced or communicated without our written agreement. |   |                             | C | - |
|   |   |                             | B | - |
|   |   |                             | A | - |

1

H G F E D C B A



500 F BLANK FLANGE

VACUUM SHAPE DOME

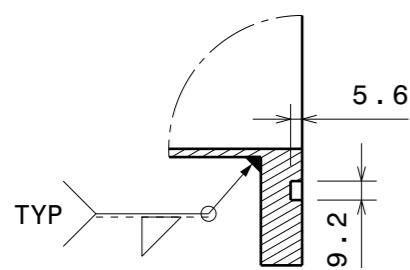

Detail E

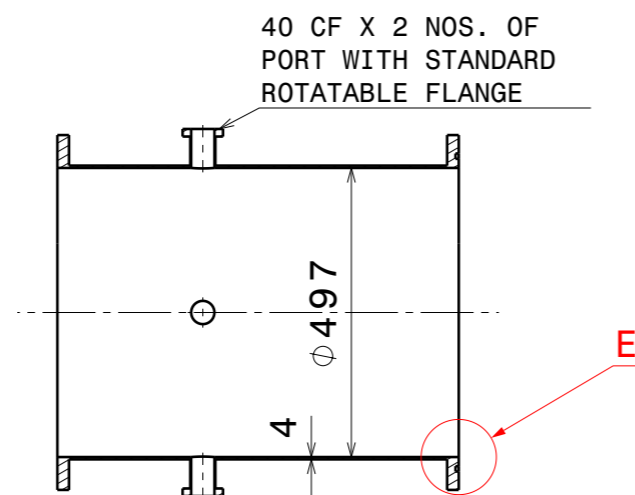

Section view D-D

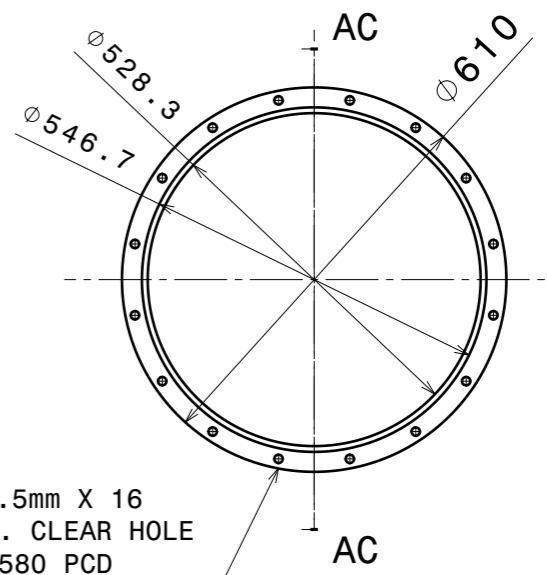

Ø13.5mm X 16 NOS. CLEAR HOLE ON 580 PCD

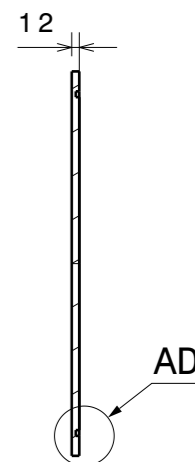

Section view AC-AC

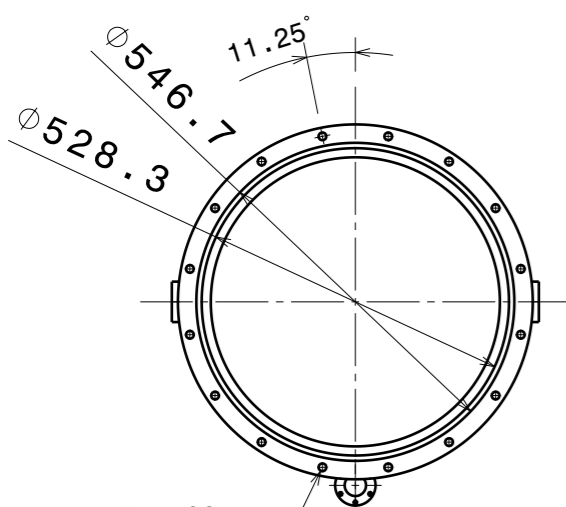

Ø13.5mm X 16 NOS. CLEAR THROUGH HOLE ON 580 PCD

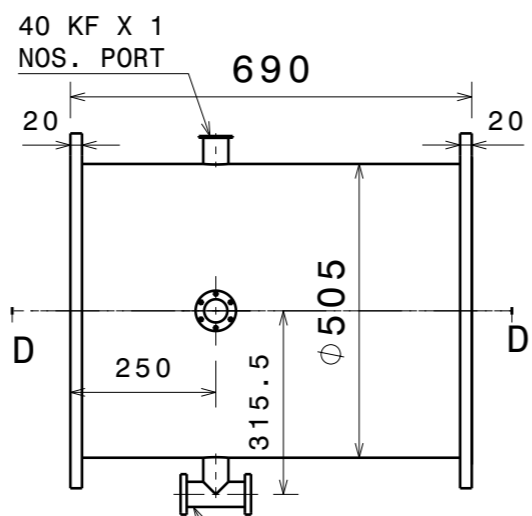

40 CF X 1 NOS. OF TEE PORT WITH ROTATABLE FLANGE

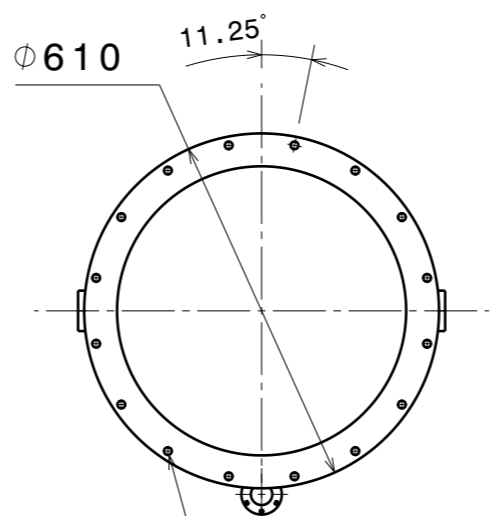

Ø13.5mm X 16 NOS. CLEAR HOLE ON 580 PCD

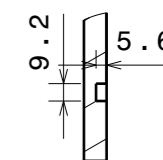
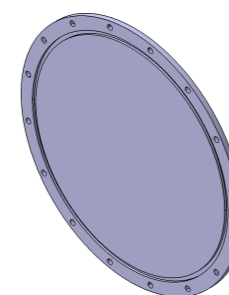

Detail AD

ALL DIMETIONS ARE IN MM

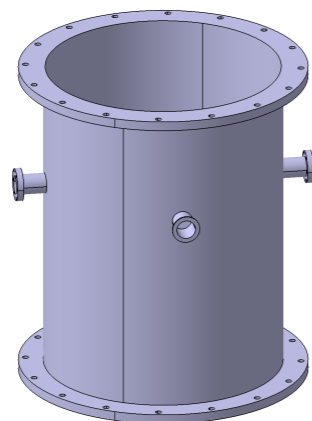
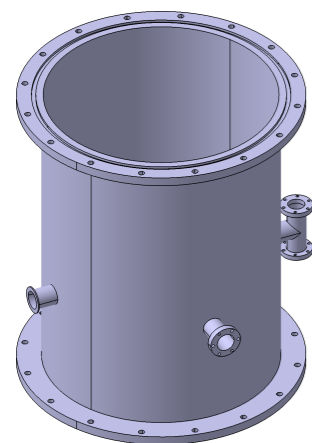

FLANGE AND PORTS ARE AS PER STANDARD  
ALL DIMENTIONS ARE IN MM

|              |             |                |
|--------------|-------------|----------------|
| DESIGNED BY: | ranjana     |                |
| DATE:        | 21-09-2020  |                |
| CHECKED BY:  | XXX         |                |
| DATE:        | XXX         |                |
| SIZE         | A3          |                |
| SCALE        | WEIGHT (kg) | DRAWING NUMBER |
|              | 62.89       |                |

|   |  |   |   |
|---|--|---|---|
| INSTITUTE FOR PLASMA RESEARCH   |  | I | - |
|   |  | H | - |
| VACUUM SHAPE DOME AND BLANK FLANGE  |  | G | - |
|   |  | F | - |
| 1:12 & 12:12  |  | E | - |
|   |  | D | - |
| SHEET 3/6   |  | C | - |
|   |  | B | - |
| This drawing is our property; it can't be reproduced or communicated without our written agreement. |  | A | - |

# STEEL TUBE

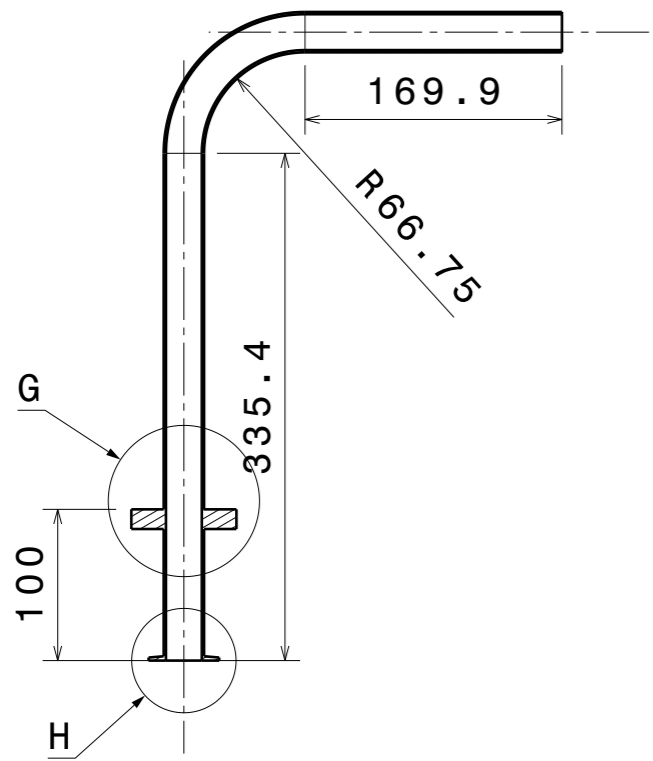
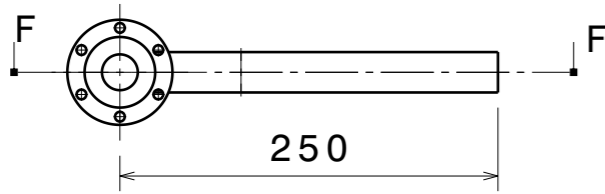

Section view F-F

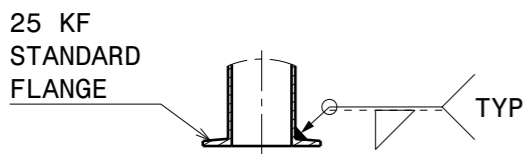

Detail H

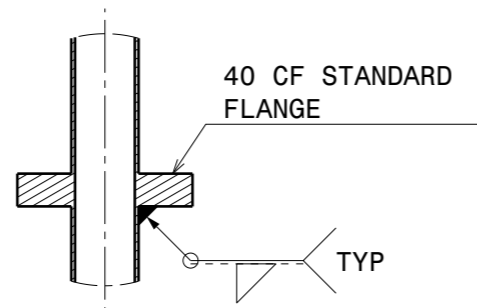

Detail G

ALL DIMENSIONS ARE IN MM

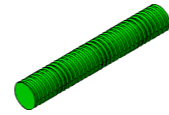
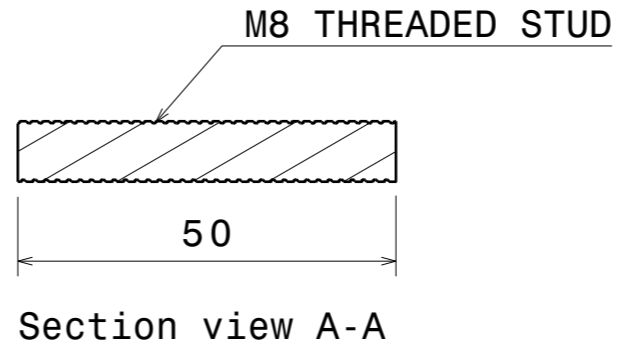
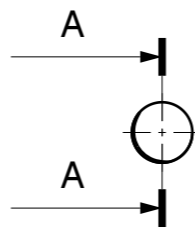

G10 STUD

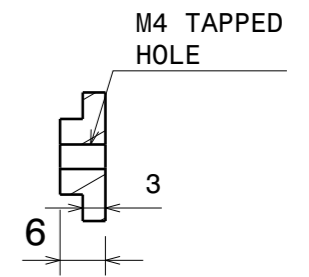
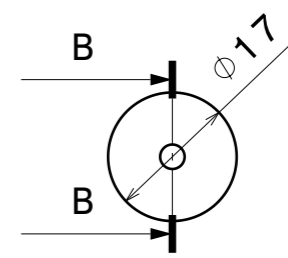

Section view B-B

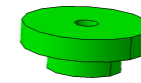

G10 BUSH

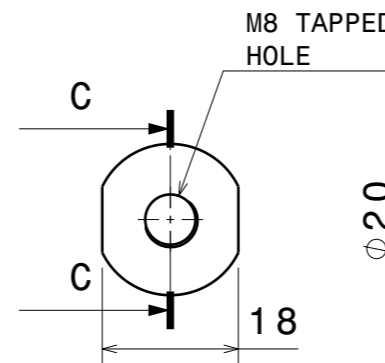

Section view C-C

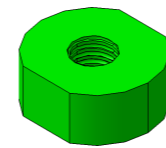

G10 NUT

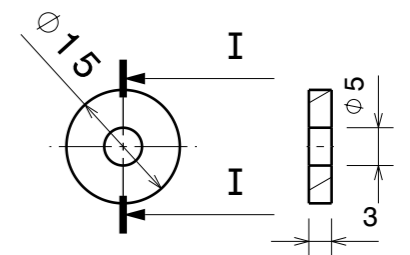

Section view I-I

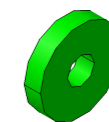

G10 WASHER

|                         |  |   |   |   |
|-------------------------|--|---|---|---|
| DESIGNED BY:<br>ranjana | INSTITUTE FOR PLASMA RESEARCH                    |   | I | - |
| DATE:<br>10-09-2020     |  |   | H | - |
| CHECKED BY:<br>XXX      | Steel tube, G10 STUD, G10 NUT, G10 BUSH & WASHER |   | G | - |
| DATE:<br>XXX            |  |   | F | - |
| SIZE<br>A3              | WEIGHT (kg)<br>0.92                              | DRAWING NUMBER<br>2:12 & 9:12 & 10:12 & 11:12 | E | - |
| SCALE                   |  |   | D | - |
|                         |  |   | C | - |
|                         |  |   | B | - |
|                         |  |   | A | - |

This drawing is our property; it can't be reproduced or communicated without our written agreement.

SHEET  
4/6

# STUD

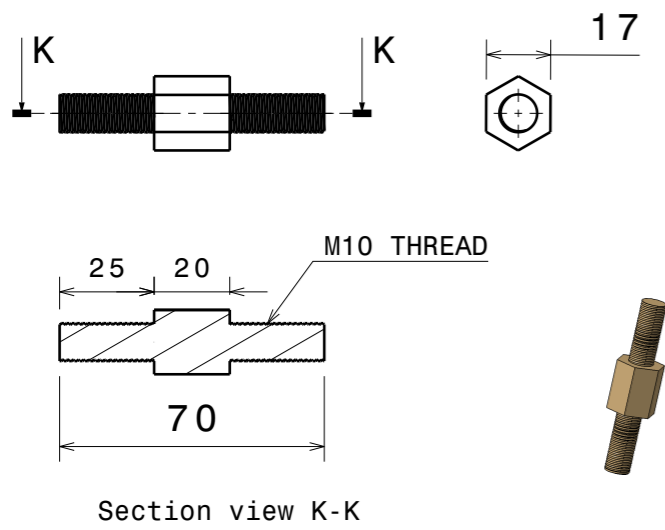

M10 TAPPED HOLE

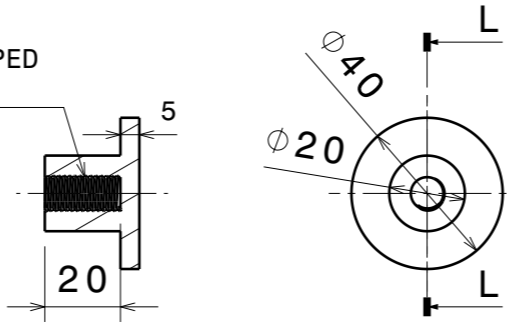

# BASE SUPPORT

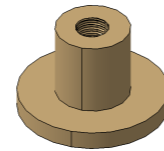

# COPPER PLATE

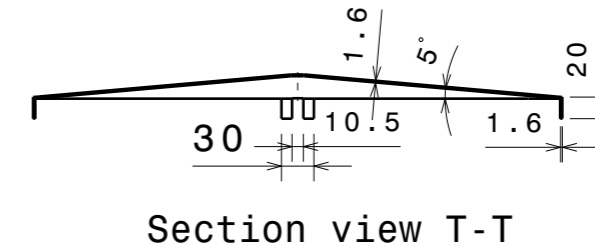
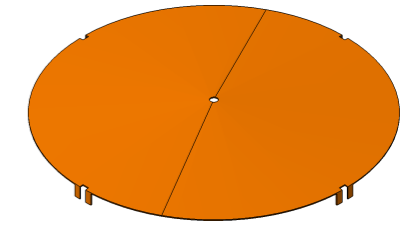

# MOUNTING STAND

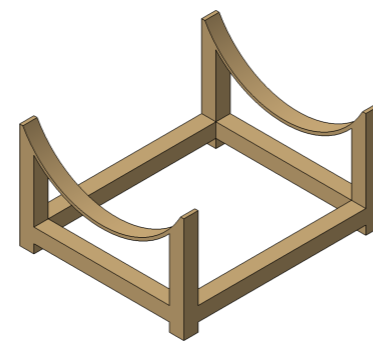
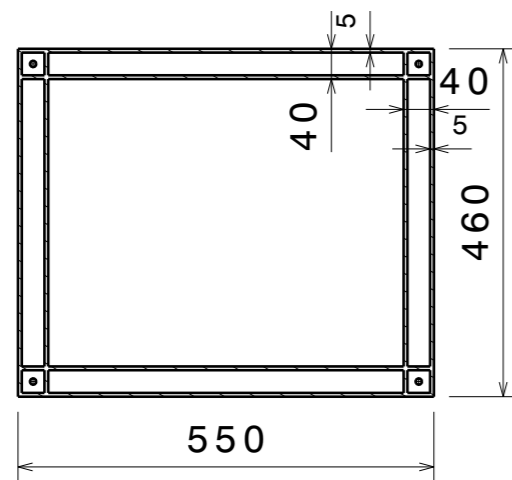
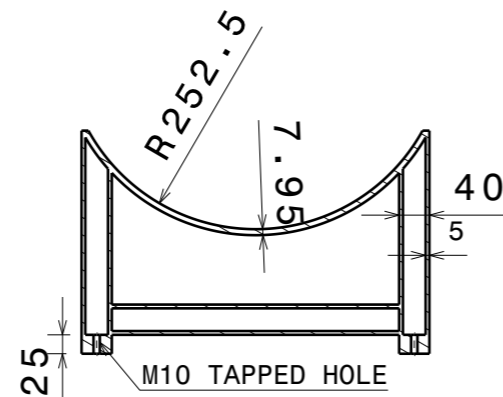
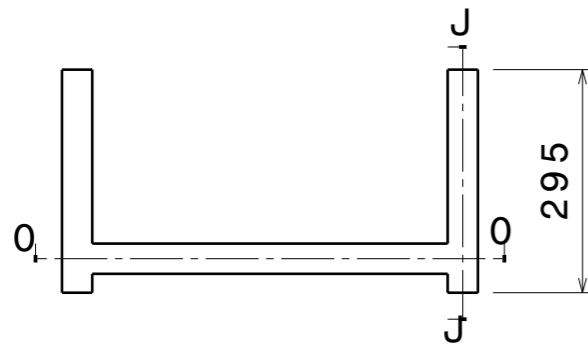

ALL DIMETIONS ARE IN MM

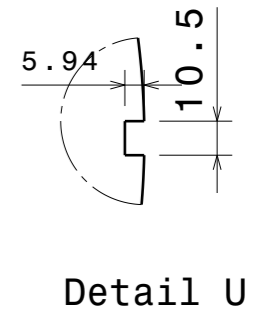
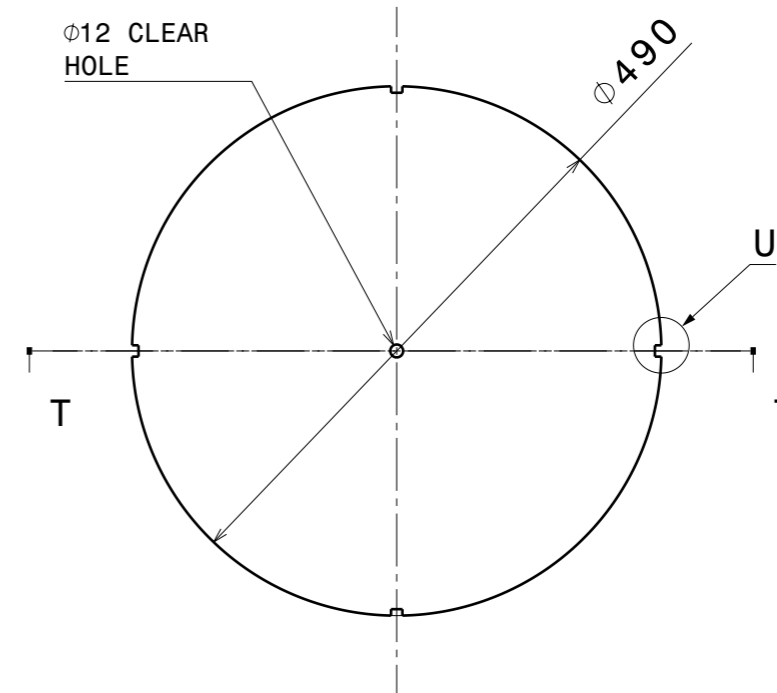

|   |  |              |   |   |
|---|--|--------------|---|---|
| DESIGNED BY:<br>ranjana   | INSTITUTE FOR PLASMA RESEARCH                                  |              | I | - |
| DATE:<br>10-09-2020   |  |              | H | - |
| CHECKED BY:<br>XXX  | Mounting Stand, Stud and Base support for stand & copper plate |              | G | - |
| DATE:<br>XXX  |  |              | F | - |
| SIZE<br>A3  | DRAWING NUMBER<br>3:12, 4:12, 5:12 & 7:12                      | SHEET<br>5/6 | E | - |
| SCALE   |  |              | D | - |
| WEIGHT (kg)<br>0.07   |  |              | C | - |
|   |  |              | B | - |
| This drawing is our property; it can't be reproduced or communicated without our written agreement. |  |              | A | - |

H G F E D C B A

TOP PART OF DOME

COOLING TUBE

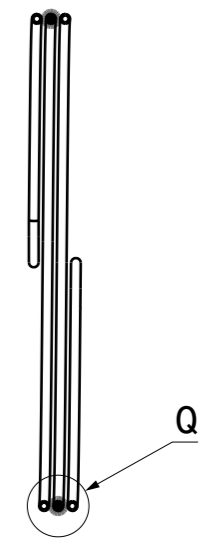
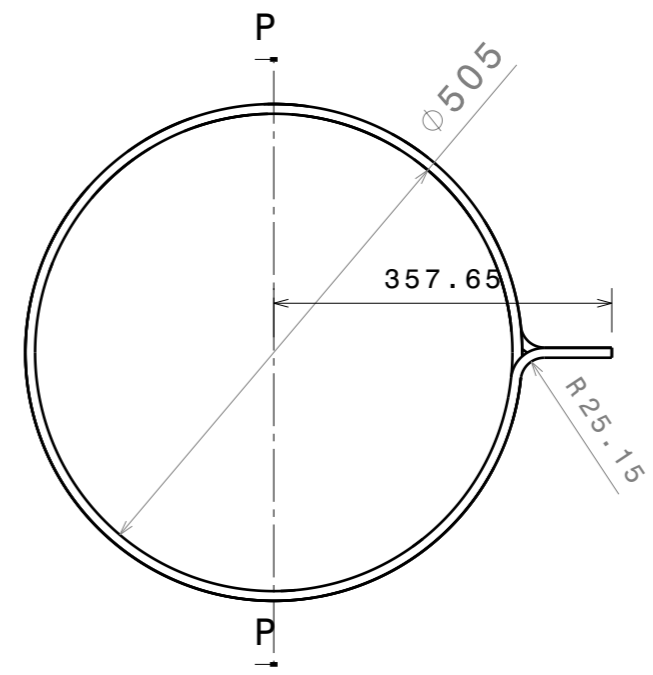
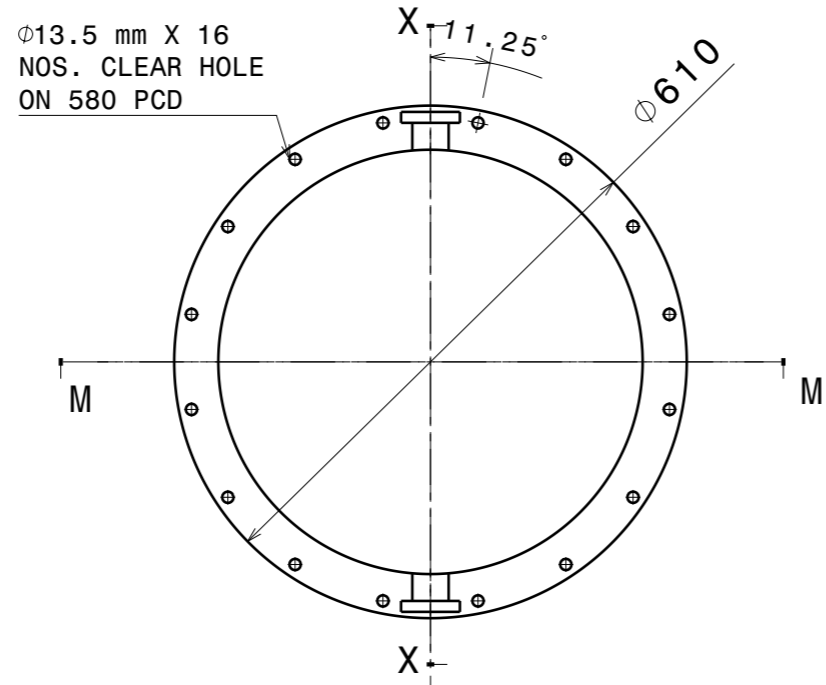
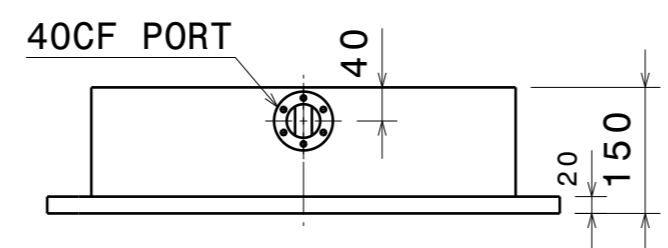
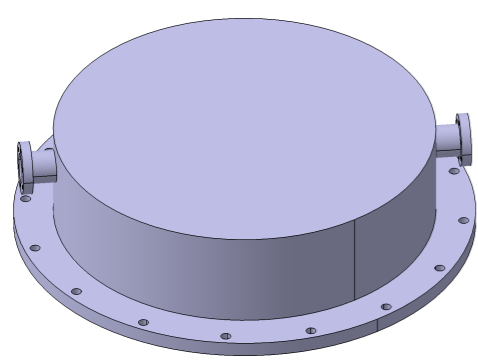

Section view P-P

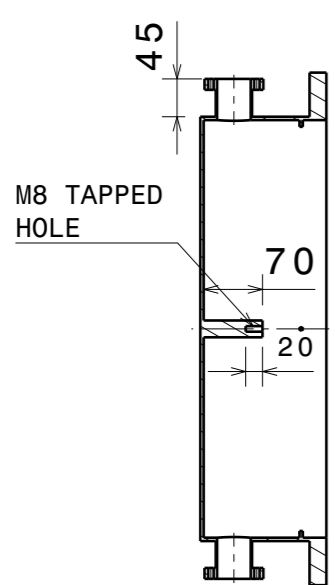

Section view X-X

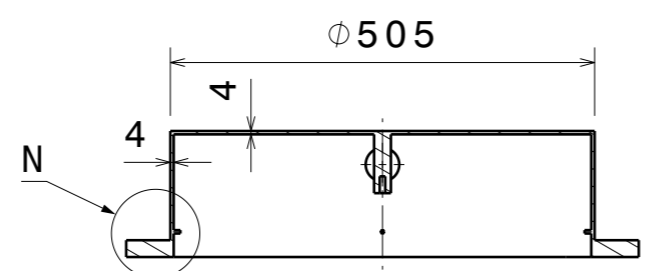

Section view M-M

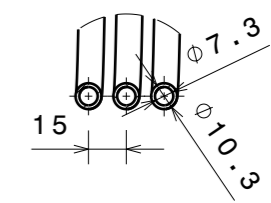
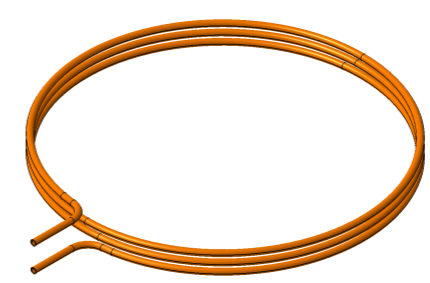

Detail Q

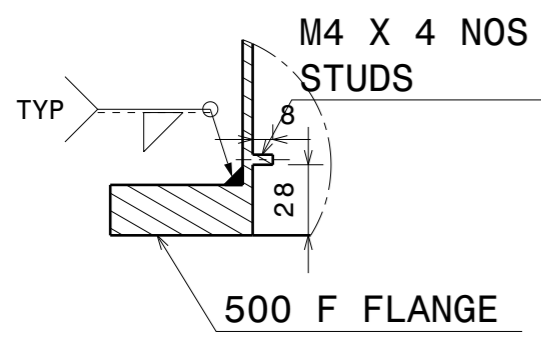

Detail N

ALL DIMETIONS ARE IN MM

|   |                                 |                                |   |   |
|---|---------------------------------|--------------------------------|---|---|
| DESIGNED BY:<br>ranjana   | INSTITUTE FOR PLASMA RESEARCH   |                                | I | - |
| DATE:<br>21-09-2020   |                                 |                                | H | - |
| CHECKED BY:<br>XXX  | Top part of Dome & Cooling tube |                                | G | - |
| DATE:<br>XXX  |                                 |                                | F | - |
| SIZE:<br>A3   | WEIGHT (kg):<br>28.30           | DRAWING NUMBER:<br>6:12 & 8:12 | E | - |
| SCALE:  |                                 | SHEET:<br>6/6                  | D | - |
| This drawing is our property; it can't be reproduced or communicated without our written agreement. |                                 |                                | C | - |
|   |                                 |                                | B | - |
|   |                                 |                                | A | - |

H G F E D C B A

(This need to be printed in Bidders letter head)

1. Please quote with complete technical details along with technical compliance sheet.
2. Quotation should be submitted in the format given below, else IPR shall not consider the offer by the vendor.

**NAME OF PARTY :** \_\_\_\_\_

**ENQUIRY NO:** \_\_\_\_\_

**QUOTATION No. & DATE :** \_\_\_\_\_

Currency of Quotation: **Indian Rupees**

| Sr. No. | Item Description | HSN/SAC Code | Quantity | Unit Rate (Basic) | Packaging & forwarding (P&F) | Applicable GST | Rate (incl P&F and GST) | Total Value |
|---------|------------------|--------------|----------|-------------------|------------------------------|----------------|-------------------------|-------------|
|         |                  |              | a        | b                 | c                            | d              | e = b + c + d           | f = a * e   |
| 1       |                  |              |          |                   |                              |                |                         |             |
| 2       |                  |              |          |                   |                              |                |                         |             |
| 3       |                  |              |          |                   |                              |                |                         |             |
| 4       |                  |              |          |                   |                              |                |                         |             |
| 5       |                  |              |          |                   |                              |                |                         |             |
| 6       |                  |              |          |                   |                              |                |                         |             |

| Sr. No. | Particular                     | Remarks |
|---------|--------------------------------|---------|
| I.      | Ex-works / FOR Destination     |         |
| II.     | Freight                        |         |
| III.    | Insurance                      |         |
| IV.     | Delivery Period                |         |
| V.      | Payment (IPR terms will apply) |         |
| VI.     | Guarantee / Warrantee          |         |
| VII.    | Validity Period                |         |
| VIII.   | Discount (if any)              |         |
| IX.     | Remarks                        |         |

Place: Authority Signatory

Date: Company Seal

**Note:**

1. Bidder should submit the copy of GSTIN / ARN Certificate along with the offer
2. Bidder should specify the SUPPLY and SERVICE rates/ charges separately wherever applicable



**Form No: IPR-MFW-01.V1**

### INSTRUCTIONS TO BIDDERS AND TERMS AND CONDITIONS

1. The Quotation and any order resulting from this enquiry shall be governed by our Conditions of Work Order and Contractor quoting this enquiry shall be deemed to have read and understood the same completely.
2. Where counter terms and conditions have been offered by the Tenderer, the same shall not be deemed to have been accepted by IPR unless our specific written acceptance thereof is obtained.
3. **Quotation:** Quotation should be submitted in the prescribed QUOTATION FORMAT attached with this Enquiry and the same should be submitted in a sealed envelope super-scribing the same with our enquiry No., date, due date and brief description of item on or before the due date. Late/delayed/incomplete/unsigned quotations will not be considered. Envelopes received without Enquiry number, date, due date and brief description of item may be rejected. The quoted prices should be firm for a period of 90 days from due date for placing order. IPR is not bound to accept lowest rate/s. IPR reserves the right to place on one or more parties. The scope of supply includes insurance by the Contractor.
4. **Specifications:** Goods should be offered strictly confirming to our specifications/drawings. Deviation, if any, should be clearly indicated by the contractor in their quotation. The Tenderer should also indicate the Make/Type number of the goods offered and catalogues, technical literature and samples, wherever necessary should accompany the quotation. Clarification/s on drawings should be obtained before submitting quotation.
5. **Terms of Prices:** Quotation should be submitted on door delivery basis without extra charge wherever possible. For quotations on Ex-Works, Ex-godown basis the approximate packing and forwarding charges should be indicated by the contractor. In the case of local contractors, the goods are to be delivered at our stores free of charge.
- 5.1 In respect of tenders on Ex-works basis, in case the tenderer has not mentioned in the offer packing, forwarding and transportation charges for safe delivery up to Purchaser's site, 2% of the price quoted towards packing (in respect of both local and outstation firms), 1% of the basic price quoted towards safe delivery charges in respect of local tenderer and 3% of the basic price quoted towards safe delivery charges in respect of outstation firm will be added for comparison of offers on safe door delivery at Purchaser's site.
- 5.2 Prices are required to be quoted according to the units indicated in the tender form/Enquiry. When Quotations are given in terms of units other than those specified in the tender form, relationship between the two sets of units must be furnished
6. Tender should be free from Correction and Erasures. Corrections, if any, must be attested. All amounts shall be indicated both in words as well as in figures. Where there is difference between amounts quoted in words and figures, amount quoted in words shall prevail. Unsigned quotations will summarily be rejected. If there is a discrepancy between the unit price and total price, unit price shall prevail.
7. IPR shall be under no obligation to accept the lowest or any tender and reserves the right of acceptance of the whole or any part of the tender or portion of the quantity offered and the tenderers shall supply the same at the rate quoted.
8. **Goods & Services Tax (GST):** The details of Taxes/GST and other levies legally applicable and intended to be claimed should be clearly indicated in the tender. Where this is not done, no claim on these accounts would be admissible later.

**a) GST for Goods (IGST/CGST/SGST TAX BENEFITS):**

IPR is entitled to avail tax benefit as per the following notifications issued by Ministry of Finance, Department of Revenue, Government of India:

(1) No: 47/2017-INTEGRATED TAX (RATE) DATED 14/11/17 for IGST

(2) No: 45/2017-CENTRAL TAX (RATE) DATED 14/11/17 for CGST

And,

IPR is entitled to avail tax benefit as per the following notifications issued by Finance Department, Government of Gujarat:

(1) No. 45/2017-STATE TAX (RATE) DATED 15/11/17 for SGST

As per above notifications IPR will bear only 5% IGST for procurement of goods from outside Gujarat & 2.5% CGST and 2.5% SGST (total 5%) for procurement of goods within Gujarat. Vendors are required to charge tax as per these notifications while quoting/supplying the goods. Deviations, (if any) should be clearly mentioned in the quotation/offer.

**Please specify the HSN codes while quoting.**

**b) GST for Services:**

As applicable. **Specify the SAC codes wherever services are involved.**

9. **Delivery Date:** Delivery period is essence of the Contract. Contractor must indicate the firm delivery date by which the goods will be dispatched or delivered by them from the date of our order. Delivery period shall be clearly



# प्लाज़्मा अनुसंधान संस्थान

) भाट, इन्दौरा पुल के पास, गांधीनगर - 382428, गुजरात (भारत)

## Institute for Plasma Research

Bhat, Near Indira Bridge, Gandhinagar - 382428, Gujarat (INDIA)

Phone: +91-79-23962000 Fax: +91-79-23962277 Website: www.ipr.res.in



- indicated against each item separately.
10. **Price/ Purchase Preference:** Purchase/Price preference to industries will be given as per the policy of the Government of India in force at the time of evaluation provided their offer is in compliance with the conditions of the policy.
  11. **Liquidated Damages:** The successful Vendor/Bidder should pay liquidated damages @ ½% (half percent) of the total work order value for the delay of each week in the scheduled date of completion of the work envisaged in the Work Order subject to a maximum of 5% (Five percent) of the total Work Order value.
  12. **Inspection:** Goods on its arrival at IPR will be inspected by Stores, and his decision in the matter will be final. However, where the items are required to be inspected at the Contractors Premises, Contractor has to give advance notice regarding readiness of the Goods to enable us to depute our representative for inspection.
  13. **Payment:** Payment will be arranged for accepted goods only within 30 days from the date of receipt of goods at IPR and bills in our accounts section, completed in all respects.
  14. No correspondence will be entertained within 30 days from the date of receipt of good and bills, whichever is later.
  15. **Guarantee:** The Stores offered should be guaranteed for a minimum period of twelve months, from that date of acceptance, against defective Goods, design, workmanship, operation or manufacture. For defects noticed and communicated during the Guarantee period, replacement/rectification should be arranged free of cost within a reasonable period of such notifications. In case where our specifications call for a guarantee period more than 12 months specifically, then such a period shall apply.
  16. **Performance Bank Guarantee:** If demanded by IPR, the successful bidder will have to furnish Performance Bank Guarantee for 10% of the order value (basic price) from a Nationalized/Scheduled Bank/State Bank of India, valid throughout the Guarantee/Warranty period. The scheduled banks approved by IPR are Axis Bank, HDFC Bank, ICICI Bank and IDBI Bank. Bank Guarantees submitted other than from banks approved by IPR will not be accepted.
  17. **Security Deposit:** If demanded the successful Bidder will have to furnish to the Purchaser an interest free security deposit for 10% (Ten percent) of the order value in the form of Bank Guarantee of an equivalent amount from a nationalized/ scheduled Bank/State Bank of India within 15 days from the date of work order and the said Guarantee should be valid till the goods are accepted by IPR. The scheduled banks approved by IPR are Axis Bank, HDFC Bank, ICICI Bank and IDBI Bank. Bank Guarantees submitted other than from banks approved by IPR will not be accepted. The Security deposit shall be forfeited in case the selected Bidder does not start the work within the time limit specified or fail to complete the work within the stipulated delivery period or fail to comply with any of the terms and conditions in the work order. On successful completion of scope of work and its acceptance by IPR, Contractor should send a letter requesting return of the original BG.
  18. The Contractor shall at all times indemnify the purchase against all claims which may be made in respect of the stores for infringement of any right protected by Patent Registration of design or Trade Mark and shall take all risk of accidents or damage, which may cause failure of supply from whatever cause arising and the entire responsibility for sufficiency of all means used by him for the fulfilment of the contract.
  19. **Free Issue Material (FIM):** Successful tenderer will have to arrange insurance showing beneficiary as "Institute for Plasma Research" at their risk and cost towards adequate security for the materials/property provided/issued by the Purchaser as Free Issue Material for the due execution of the contract.
  20. The Director, IPR reserves the right to accept or reject any quotations fully or partly or to cancel the enquiry without assigning any reason.
  21. **Jurisdiction:** The contract shall be governed by the Laws of India for the time being in force. The Courts of Gandhinagar only shall have jurisdiction to deal with and decide any legal or dispute arising out of this Contract.