

Tender document
For Design, fabrication, supply, installation and commissioning
of Waste Feeder Chamber and Primary Chamber assembly

Contents

1. Introduction	3
1.1. Waste feeder chamber assembly	3
1.2. Primary chamber assembly	4
2. Scope of work	4
3. Code and Standard	7
4. Technical specification	7
4.1. Waste feeder chamber assembly	7
4.2. Primary chamber assembly	8
5. Materials.....	9
6. Instruction to vendor.....	10
7. Machining, Fabrication and cleaning	11
8. Lining materials installation.....	11
9. Inspection and Testing procedure.....	12
10. Acceptance test.....	14
10.1. Factory Acceptance Test (FAT)	14
10.2. Site Acceptance Test (SAT)	15
11. Delivery schedule	15
12. Document to be submitted	16
13. Insurance, packing, handling and Supply	16
14. Guarantee/warranty.....	16
15. Post warranty support.....	17
Annexure – I.....	17
Annexure – II.....	17
Annexure – III.....	18
Annexure – IV.....	19

1. Introduction

Pyrolysis system comprises of various subsystems such as feeder chamber, primary chamber, gas cleaning system, induce draft fan, chimney, etc. There will be high temperature at wall of nearly 1000°C inside the primary chamber generated using plasma arc. A limited volume waste bag of nearly 10kg is fed in this hot primary chamber using the feeder chamber.

The schematic of waste feeder chamber and primary chamber assembly is shown in Figure 1 and Figure 2 below. The operation and functional details of feeder chamber and primary chamber are briefed in sub-section 1.1 and 1.2 respectively.

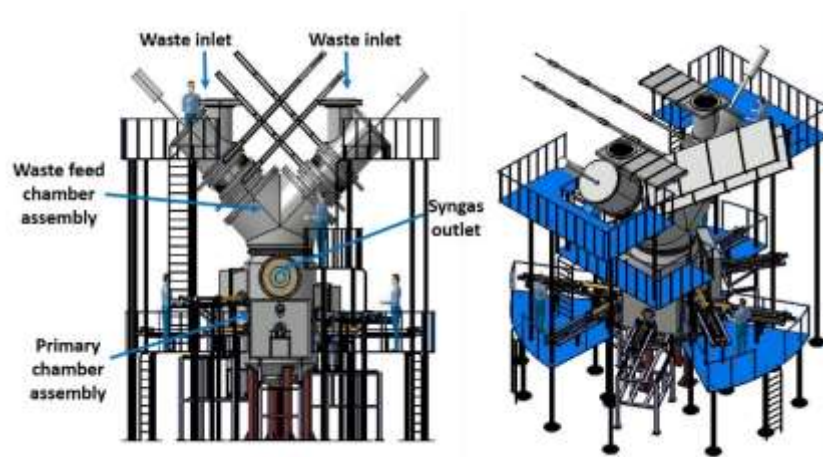

Figure 1: Waste feeder chamber and primary chamber assembly including conceptual support structure and service platform

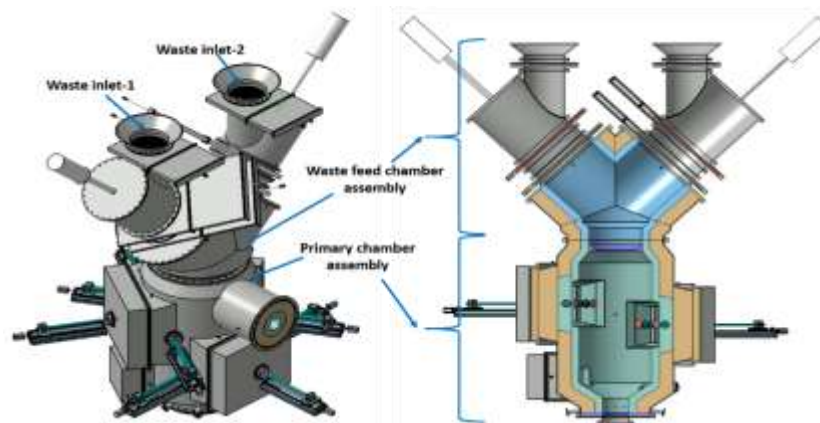

Figure 2: waste feed chamber and primary chamber assembly only

1.1. Waste feeder chamber assembly

The feeder chamber is used for feeding the waste packets into the primary chamber through the gate valve operation. Feeder chamber assembly consists of two feeder chambers which have feeder chamber ports, feeder chamber manifold, service platform and support structures for feeder chamber, plunger mechanism and service platform. The dimensions of interfacing components (i.e. gate valves and plunger mechanism will be provided by IPR during execution of work. The schematic of feeder chamber assembly is shown in Figure 3. The material of construction (MOC) for feeder chamber assembly is specified in the drawings under Annexure-I. The detailed technical specification of waste feeder chamber assembly is given in sub-section 4.1.

TENDER NO. IPR/TN/PUR/TPT/ET/20-21/10 DATED 31/12/2020

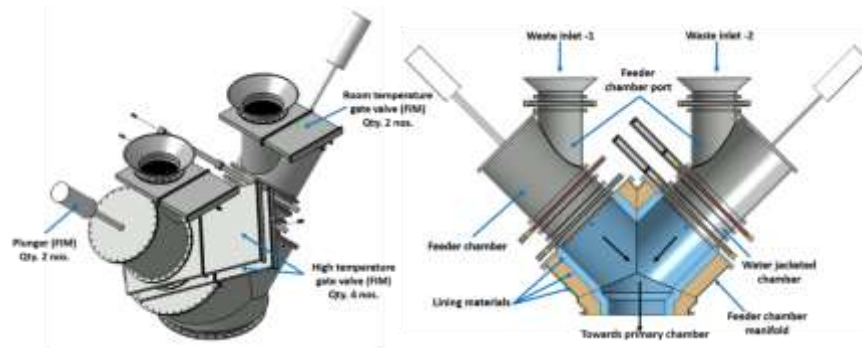

Figure 3: Waste feeder chamber assembly (Isometric view and sectional view)

1.2. Primary chamber assembly

There will be high temperature of nearly 1000°C on the wall inside the primary chamber. Primary chamber assembly consists of electrode port, auxiliary port, gas outlet pipe, and service platform and support structure for primary chamber, door for electrode port and door for auxiliary port. The lining material is composed of (a) refractory layer; (b) insulation layer type 1 and (c) insulation layer type 2 (The details of all these insulation layer is given under respective annexures) which is used to minimize the heat losses. The schematic of primary chamber is shown in Figure 4 and Figure 5. The dimensions of interfacing components (i.e. electrode assembly) will be provided by IPR during execution of work. The material of construction (MOC) for primary chamber assembly is specified in the drawings under Annexure-I. The detailed specifications of primary chamber assembly is given in sub-section 4.2.

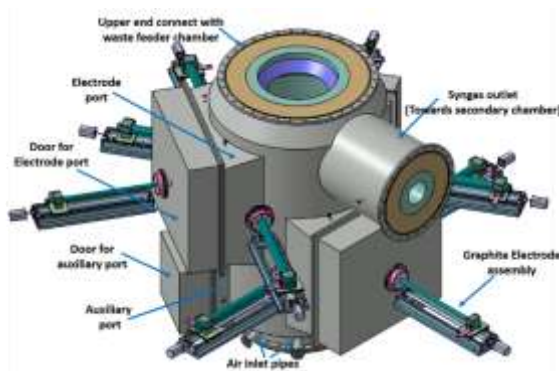

Figure 4: Primary chamber assembly

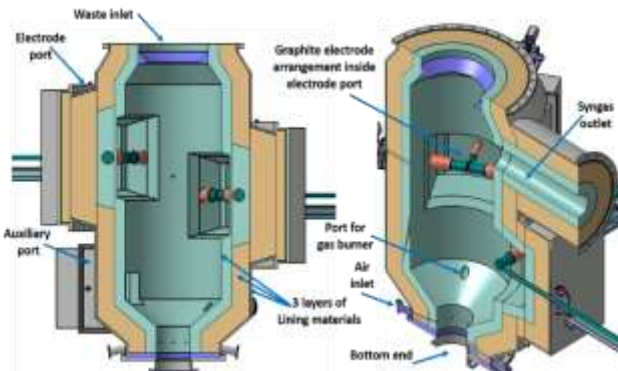

Figure 5: Internal detail of primary chamber assembly

2. Scope of work

- 2.1. The job consists of three items (1) Waste feeder chamber assembly, (2) Primary chamber assembly and (3) support structure and service platform for various components and sub-assemblies mentioned in the point 2.7 below. The design and analysis of item no. (1) & (2) is performed by IPR and respective engineering drawings are attached in Annexure-I. The vendor shall responsible for fabrication, inspection, installation and commissioning of components and sub-assemblies as per tender specification for item no. (1) & (2). For item no. (3), Vendor shall responsible for design, analysis, fabrication, inspection, erection and commissioning as per tender specification.
- 2.2. Vendor shall be responsible for raw material procurement, precision fabrication, lining material installation, welding joints, assembly, inspection, testing, supply, installation and commissioning of the waste feeder

TENDER NO. IPR/TN/PUR/TPT/ET/20-21/10 DATED 31/12/2020

chamber assembly and primary chamber assembly as per the IPR's tender specifications & engineering drawing attached in Annexure-1.

- 2.3. Vendor shall prepare 3D CAD model, detailed manufacturing/fabrication drawings of components and assemblies with tolerance from supplied IPR's engineering drawings and submit to IPR for approval.
- 2.4. The Vendor shall quantify structural materials, lining materials, high temperature gasket, etc. for successful fabrication, inspection, assembly, testing and commissioning of waste feeder chamber and primary chamber assembly. Detailed Bill of Material (BOM) to be submitted to IPR for review and approval before start of procurement.
- 2.5. Vendor shall also prepare a list of additional items, if any, such as anchor, clamp, suitable binder, mortar, retaining plate/ring, oxidizing materials etc. which would be necessary for holding and installing lining materials inside waste feeder chamber and primary chamber assembly. Vendor shall also have to submit BOM of such items to IPR for review and approval before start of procurement.
- 2.6. Vendor shall also design, analysis and supply the following;
 - a) Suitable support structure for erection and commissioning of waste feeder chamber assembly and primary chamber assembly.
 - b) Suitable support structure for linear movement of each assembly of door that connecting to respective electrode ports and auxiliary port of primary chamber assembly.
 - c) Suitable support structure for plunger mechanism and gate valves connecting with waste feeder chamber assembly.
 - d) Suitable support structure for respective electrode assemblies those connecting with assembly of door for electrode ports and electrode ports of primary chamber assembly respectively.
 - e) Suitable service platforms to access individual components during service, repair and maintenance.
 - f) The waste feeder chamber and primary chamber assembly including support structures and service platforms are going to be installed and commissioned either at Varanasi or at Ahmedabad city after completion of site acceptance test at FCIPT, Gandhinagar. The performance of support structures and service platforms is the responsibility of the vendor. Therefore, Vendor shall perform design and analysis of support structures and service platforms considering higher risk factors applicable to either Varanasi or Ahmedabad city. The analysis shall be performed considering different load cases combination (i.e. Structural, Thermal, gravity including seismic load and other load, if applicable).
 - g) Vendor should submit the detailed support structures and service platforms design and analysis document for point 2.6 (a) to (e) to IPR for review and approval.
- 2.7. Vendor shall provide to IPR a compatible 3D CAD model of waste feeder chamber and primary chamber assembly along with support structure and service platform as designed under point number 2.6 above. Vendor shall also have to provide weight details of each component including lining materials installed in it as intimated by IPR. The thermal, structural and seismic analysis document of support structures and service platforms will be provided to IPR for review and approval. After the review, if the support structures and service platforms are found unsafe then vendor has to do the necessary changes in the design.
- 2.8. Vendor shall make arrangement of quick release mechanical clamps to connect each door leak tight with electrode ports and auxiliary port of primary chamber respectively.
- 2.9. Vendor shall make arrangement of 06 nos. ports for temperature and pressure measurement in consultation with IPR during preparation of fabrication drawings.
- 2.10. Vendor shall provide appropriate lifting lugs & hooks on various components and assemblies for safe handling, transportation and also for safe maintenance work performed using crane. The location of the lugs & hooks should be ensured considering centre of gravity of the structure.

SECTION – C

TENDER NO. IPR/TN/PUR/TPT/ET/20-21/10 DATED 31/12/2020

- 2.11. Vendor shall also be responsible for compatible interfacing of fabricated components, lining materials installed and their assembly with gate valves, plunger mechanism and electrode assembly. The dimensions and weight of interfacing components will be provided by IPR during execution of PO.
- 2.12. Vendor shall prepare components surface as per recommendation from OEM paint supplier and components should be painted externally with heat resistance alumina paint suitable to withstand temperature of 250°C with proper surface preparation.
- 2.13. Service platforms and support structures shall be painted using black color after applying two coats of suitable anti-corrosive chemical.
- 2.14. The whole structure outer wall is electrically a single conducting body which will be grounded at single point using copper bar/plate which will be bolted on the structure.
- 2.15. The vendor must follow, supply and assemble the components as per the list of preferred make prepared by IPR enclosed under Annexure –II.
- 2.16. Vendor's scope of work also includes the following points:
- a) During the preparation of fabrication/manufacturing drawings, Vendor shall also study the fabrication feasibility and shall intimate to IPR for any modifications that may seem to be necessary for successful manufacturing/fabrication of components, sub-assemblies & assembly. After approval from IPR, vendor shall incorporate necessary modifications.
 - b) The manufacturing/fabrication drawings shall clearly indicate the welding process, weld serial no. and weld joint design considered for production of joints during assembly.
 - c) Vendor must also submit the fabrication methodology plan along with time line in respect of section- 11 (Delivery schedule) of this technical specification to IPR for approval.
 - d) Vendor must also make a periodical review plan (part of MIP document) to be conducted by IPR's engineers at vendor's site.
 - e) Procurement of bought out items should be from original equipment manufacturer (OEM) or their authorized distributors/suppliers.
 - f) Procurement of all necessary raw materials, items and equipment with test certificates, wherever applicable. The test certificates should be submitted to IPR for approval.
 - g) Design, development and manufacturing of tools, jigs, fixtures and other accessories required for manufacturing of components & assemblies for waste feeder chamber assembly, primary chamber assembly and lining materials installation.
 - h) Vendor shall comply with IPR technical specification, 2D engineering drawings and check for manufacturing feasibility and process for manufacturing.
 - i) Fabrication of all components, sub-assemblies and assembly according to the approved fabrication drawings by IPR as per delivery schedule shown in section-11.
 - j) Inspection and testing of materials, components & sub-assemblies at appropriate stages before the final assembly. Supply of appropriate test report to IPR before pre-dispatch inspection to be performed by IPR's engineers.
 - k) Vendor has to conduct Factory acceptance tests in the presence of IPR's engineers.
 - l) Assembly of components and test their mechanical integrity at factory site as well as at IPR site.
 - m) Packaging and delivery of components to IPR with appropriate unloading instructions at IPR site after the dispatch clearance by IPR.

3. Code and Standard

- I. All aspects of manufacturing, welding, heat treatment, inspection, etc. shall be performed in accordance to ASME Section VIII Div-1 or Div-2 of Boiler & Pressure Vessel Code and/or relevant ASTM standards.
- II. The material shall be procured in accordance with ASME section II of Boiler & Pressure Vessel Code for Materials and relevant ASTM standards.
- III. Welding qualification shall be performed in accordance with the guidance provided in ASME section IX of Boiler & Pressure Vessel Code.
- IV. Non-destructive examinations shall be performed in accordance with procedures mentioned in ASME section V of Boiler & Pressure Vessel Code.
- V. Vendor shall define/propose additional Codes and standards as per good engineering practice for smooth execution.

4. Technical specification

4.1. Waste feeder chamber assembly

Description	Specifications
Feeder chamber manifold (FCM) assembly	<ul style="list-style-type: none"> ➤ MOC: Specified in engineering drawings under Annexure-I. ➤ Lining materials thickness: <ol style="list-style-type: none"> (a) refractory layer = 115 mm (thick) (b) insulation layer type 1 = 200 mm (thick) (c) insulation layer type 2 = 5 mm (thick) ➤ Lining material specification: lining materials should be procured as per detail given under Annexure –II and Annexure-III respectively.
Feeder Chamber 1 and Feeder Chamber 2	<ul style="list-style-type: none"> ➤ MOC: Specified in engineering drawings under Annexure-I.
Flanges	<ul style="list-style-type: none"> ➤ MOC: Specified in engineering drawings under Annexure-I. ➤ Flange Type: <ol style="list-style-type: none"> I. Rotatable type flange to be connected with adjoining component assembled at either side of gate valves with proper interface on mutual discussion (see location in relevant 2D drawings under Annexure-I). II. Integral type flange at other components as per 2D drawings. ➤ Surface finish of gasket contact area of flange should be 3∇, other area shall have 2∇.
Support structure	<ul style="list-style-type: none"> ➤ MOC: Mild Steel (M.S.) of IS 2062 GRADE E300 Quality A or BR. ➤ The support structure should enough to take load of whole assembly.
Service platform	<ul style="list-style-type: none"> ➤ MOC: Mild Steel (M.S.) of IS 2062 GRADE E300 Quality A or BR. ➤ To access individual components during service, repair and maintenance. ➤ The width for service platform shall have to accommodate minimum 3 persons during operation, repair and maintenance. ➤ The service platform should be sturdy enough to take load of minimum 3 persons and/or other structures connecting it.

	<ul style="list-style-type: none"> ➤ The design of service platform should be such that it can be dismantled and/or move away during repair/replacement of any components of waste feeder chamber assembly.
Sealing requirement	<ul style="list-style-type: none"> ➤ Ceramic fibre gasket or equivalent properties gasket of min. 5 mm thickness that can withstand temperature regime of 800⁰C - 1000⁰C ➤ Fasteners MOC: SA-193 B7 heavy hexagonal type.

Note: All dimensional details are included in the drawings. All other fabrication related details have to be worked out by vendor and approval should be taken from IPR before starting of fabrication.

4.2. Primary chamber assembly

Description	Specifications
Cylindrical chamber assembly	<ul style="list-style-type: none"> ➤ MOC: Specified in engineering drawings under Annexure-I. ➤ Lining materials thickness: <ul style="list-style-type: none"> (a) refractory layer = 115 mm (thick) (b) insulation layer type 1 = 200 mm (thick) (c) insulation layer type 2 = 5 mm (thick) ➤ Lining material specification: lining materials should be procured as per detail given under Annexure –II and Annexure-III respectively. ➤ Vendor shall design and supply support structures for connecting electrode assemblies with respective ports of primary chamber.
Assembly of door for electrode ports	<ul style="list-style-type: none"> ➤ MOC: Specified in engineering drawings under Annexure-I. ➤ Lining materials thickness: <ul style="list-style-type: none"> (a) refractory layer = 115 mm (thick) (b) insulation layer type 1 = 200 mm (thick) (c) insulation layer type 2 = 5 mm (thick) ➤ Lining material specification: lining materials should be procured as per detail given under Annexure –II and Annexure-III respectively. ➤ Vendor shall design and supply support structures for connecting electrode assemblies with port on doors. ➤ The support structure for door would rest on roller and/or guide rail and it is capable to travel minimum linear distance of 1 meter. ➤ The support structure should enough to take load of assembly of door and respective electrode assemblies.
Assembly of door for auxiliary port	<ul style="list-style-type: none"> ➤ MOC: Specified in the drawings under Annexure-I. ➤ Lining materials thickness: <ul style="list-style-type: none"> (a) refractory layer = 115 mm (thick) (b) insulation layer type 1 = 200 mm (thick) (c) insulation layer type 2 = 5 mm (thick) ➤ Lining materials specification: lining materials should be procured as per detail given under Annexure –II and Annexure-III respectively. ➤ The support structure for door would rest on roller and/or guide rail and it is capable to travel minimum linear distance of 1 meter. ➤ The support structure should enough to take load of door for auxiliary port.

TENDER NO. IPR/TN/PUR/TPT/ET/20-21/10 DATED 31/12/2020

Flanges	<ul style="list-style-type: none"> ➤ MOC: Specified in engineering drawings under Annexure-I. ➤ Flange Type: Integral type flange as per 2D drawings. ➤ Surface finish of gasket contact area of flange should be 3∇, other area shall have 2∇.
Support structure	<ul style="list-style-type: none"> ➤ MOC: Mild Steel (M.S.) of IS 2062 GRADE E300 Quality A or BR. ➤ The support structure should enough to take load of whole assembly. ➤ Support structure welded with primary chamber assembly shall be designed such that minimum clearance of 1.2 meter shall be available from floor level to the bottom part of primary chamber assembly (Please refer drawing no. IPR/APD/20/A3/CBWTF).
Service platform	<ul style="list-style-type: none"> ➤ MOC: Mild Steel (M.S.) of IS 2062 GRADE E300 Quality A or BR. ➤ To access individual components during service, repair and maintenance. ➤ The width for service platform shall have to accommodate minimum 3 persons during operation, repair and maintenance. ➤ The service platform should be sturdy enough to take load of minimum 3 persons and/or other structures connecting it. ➤ The design of service platform should be such that it can be dismantled and/or move away during repair/replacement of any components of waste feeder chamber assembly.
Sealing requirement	<ul style="list-style-type: none"> ➤ Ceramic fibre gasket or equivalent properties gasket of min. 5 mm thickness that withstand temperature regime of 800°C - 1000°C ➤ Fasteners MOC: SA-193 B7 heavy hexagonal type.

Note: All dimensional details are included in the drawings. All the other fabrication related details have to be worked out by vendor and approval should be taken from IPR before starting of fabrication.

5. Materials

- I. The components of waste feeder chamber assembly, primary chamber assembly, support structures, service platforms should be made up of the material indicated under section 4 and Annexure-II respectively.
- II. Structural materials shall be tested by the vendor in procured condition for its chemical and mechanical properties as well as for any internal defect.
- III. The lining materials shall also be tested by the vendor in procured condition for its thermo-physical properties mentioned under Annexure-III. The test certificate should clearly indicates the properties mentioned under Annexure-III for each lining material.
- IV. Vendor shall submit test certificates of structural materials and lining materials to IPR issued **by NABL accredited laboratory** for acceptance by IPR before starting of fabrication and lining work respectively at factory site.
- V. Vendor shall supply test specimens of structural materials and lining materials as per relevant ASTM standards. IPR may get the materials tested from third parties and in case, if material is found non-complying with IPR specification then the material will be rejected.
- VI. Vendor shall have to submit technical data sheet of lining materials being offered in respect of properties mentioned under Annexure- III specifying brand/make for properties verification and technical qualification.

SECTION – C

TENDER NO. IPR/TN/PUR/TPT/ET/20-21/10 DATED 31/12/2020

- VII. Vendor shall also submit test certificates of procured structural and lining materials provided by manufacturer or their authorized laboratory before starting of fabrication and lining work at factory.
- VIII. Vendor shall submit proof of materials procurement (i.e. invoice copy/challans/bills/purchase order along with delivery note from OEM/authorized distributes/dealers) in respect of Annexure-II.
- IX. Vendor shall use fastener (bolts, studs, nut, etc.) confirming to ASME/ASTM standards unless otherwise specified in this document.
- X. The maximum tightening torque value for untreated black finish bolts/studs of different size is provided below;

Nominal bolt diameter (coarse thread)	Torque (N-m)	Nominal bolt diameter (coarse thread)	Torque (N-m)	Nominal bolt diameter (coarse thread)	Torque (N-m)
M6	10.5	M12	89.0	M20	420.0
M8	26.0	M14	141.0	M22	570.0
M10	51.0	M16	215.0	M30	1450.0

6. Instruction to vendor

- I. IPR reserves right to participate and review the progress of the work at any stage. The vendor shall agree to make appropriate arrangement for this at vendor's premises or at any other place where such activities may be carried out.
- II. IPR will have exclusive right on the activities related to work contract and the vendor shall not disclose any information to others at anytime, anywhere without prior written permission from IPR as it is highly confidential.
- III. All documents related to fabrication submitted by vendor shall be the intellectual property of IPR.
- IV. Any deviation / discrepancy / change from the drawings shall be brought out in separate sheet by the vendor.
- V. The vendor shall provide proper aesthetic to feeder chamber and primary chamber assembly along with support structures and service platform.
- VI. All scaffolding, hoisting arrangements, lifting devices, tools, ladders and equipment's etc. required for facilitating of frame structure erection at FCIPT shall be provided and removed on completion work by the vendor, at vendor's own expense. The scaffolding, hoisting arrangement, ladders etc. shall be strong enough to withstand all live, dead and impact loads expected to act. However, Vendor shall be solely responsible for the safety of the scaffolding, hoisting arrangement, ladders, work and workmen, personnel etc.
- VII. Supply and installation of Hardware needed for supporting like Clamps/Steel Chain for mounting, Bolts/Nuts, Anchor bolts and Screws for mounting on other Structure shall be borne by the vendor during the execution of the work.
- VIII. Erection in general, of the entire/part structure shall be carried out as per the requirement. Positioning and levelling of the structure, alignment and plumbing and fixing every member of the structure shall be in accordance with the relevant drawings and to the complete satisfaction of IPR.
- IX. Qualified welders, fitters, painters and other manpower required for workmanship (like steel works, cutting, welding, bolting, material handling, painting etc.) for assembly and erection of feeder chamber, primary chamber and sub-assemblies.

TENDER NO. IPR/TN/PUR/TPT/ET/20-21/10 DATED 31/12/2020

- X. All standard safety measures have to be followed during execution of the work. The Vendor shall be responsible for comprehensive workmanship compensation insurance for any accidents/incidents of the personnel at IPR work site.
- XI. The rate includes cost of all material, labour, erection, hoisting, scaffolding, safety measures and sundry required for proper completion of the item of work, at all heights. This shall also include transportation and delivery, handling, loading, unloading and storing etc. required for completion the item described above including necessary wastage involved.

7. Machining, Fabrication and cleaning

- I. The cutting of materials from the supplied lot should ensure sufficient margin to avoid heat affected areas causing material degradation.
- II. During machining, the cutting fluids used shall be water soluble, non-halogenated and phosphorus and sulphur free.
- III. The components/assemblies shall be mechanically cleaned for removal of all weld tacks, sharp edges & projections, dust and particles generated during grinding. Remove gross contamination from all interior and exterior surfaces (including flange faces) by cleaning.
- IV. All surfaces shall be grounded smooth to 2V surface finishes unless otherwise specified.
- V. Machined parts and fabricated components shall be degreased using solvents or alkaline detergents, rinsed with demineralized water, and dried completely before starting welding job.
- VI. Vendor has to submit WPS, PQR, and WPQ and weld plan to IPR for approval before executing the work.
- VII. Vendor shall provide assembly marking on fabricated components for ease of assembly and disassembly of components of assemblies during repair and maintenance.
- VIII. The welding shall be carried out only by qualified welders. Qualification of welders shall be accordance with the requirements of ASME Boiler and Pressure Vessel Code, Section IX.
- IX. Full penetration weld should be employed wherever it is possible. Trapped volume should be avoided during welding.
- X. Single pass weld up to a maximum extent is preferred. Interruption during welding should be reduced to a minimum possible extent.
- XI. If leak develops; weld metal shall be removed and joint shall be re-welded with appropriate weld repair procedure.
- XII. Filler material, if used, should be compatible with the parent material.
- XIII. All welds should be grounded smooth and flush with adjoining surfaces with convex curvature.
- XIV. Remove material markings etc. with acetone followed by cleaning with Phosphate free alkaline detergent and rinsing with DM water.
- XV. Drying will be accomplished by blowing clean dry air over the component. Inspect and cover the component as soon after drying as possible and store in clean area. Avoid contamination from unfiltered shop air.
- XVI. Immediately after inspection, cover the components with double wrap of clean, oil-free polyethylene and seal them.

8. Lining materials installation

- I. Vendor shall start installation of lining materials at factory after getting acceptance form IPR on submitted test certificates of lining materials.

TENDER NO. IPR/TN/PUR/TPT/ET/20-21/10 DATED 31/12/2020

- II. Vendor shall carry out lining material installation as per approved fabrication drawings including lining work.
- III. IPR representative will witness lining materials installation work carried out by vendor at factory site.
- IV. Vendor shall deploy adequate number of skilled refractory masons and experienced supervisors along with un-skilled workers as per lining work job at factory site.

9. Inspection and Testing procedure

- I. All fabrication drawings with dimensions and tolerances shall be checked and should be submitted to IPR for necessary approval.
- II. IPR representative shall have access to all manufacturing and fabrication facilities, inspection and testing facilities, tools, drawings etc. during all stages of manufacturing.
- III. Vendor has to submit final fabrication drawings and testing reports to IPR, based on which, IPR can decide to do or not to do the Pre-dispatch Inspection.
- IV. The components manufacturing, fabrication and assemblies should be done as per tolerances given in ASME Y14.5 and IS 2102-1 1993/ISO 2768 tolerance class c respectively.
- V. All the components and/or sub-assemblies should be checked for surface finish and dimensional accuracy. Vendor has to submit the dimensional check and surface check report for components and assemblies.
- VI. Radiography test shall be carried out for weld joints wherever possible, otherwise alternative NDT methods may be used.
- VII. All the components shall be delivered only after shipment clearance from IPR.
- VIII. The preferred inspection and/or testing methods and respective acceptance criteria are described below;

a) Visual inspection

- (i) Visual inspection shall be performed as per ASME Section V_Subsection A - Article 9.
- (ii) Visual inspection of components for any defects, crack, flaws etc.
- (iii) A visual inspection shall be made of exterior and interior surfaces.
- (iv) Visible particulates or actual contamination shall be removed.

b) Liquid Penetrant Test (LPT)

- (i) All welded joints shall be tested by vendor with Liquid Penetrant Test as per guidance provided in ASME Section V_Subsection A - Article 6.
- (ii) The Liquid Penetrant tested areas shall be cleaned by hot detergent wash. The water temperature shall be kept at 60°C and then these tested areas shall be dried completely. In case, vendor finds unacceptable defect, the same shall be notified to IPR.
- (iii) The procedure for testing shall be submitted to IPR for review and approval.
- (iv) Acceptance criteria;
 - (1) Imperfections producing indications with major dimensions greater than 1/16 in. (1.5 mm) shall be considered relevant imperfections.
 - (2) Imperfections producing the following indications are also unacceptable:
 - Any cracks or linear indications with length three times greater than the width;
 - Rounded indications with dimensions greater than 3/16 in. (5 mm);
 - Four or more rounded indications in a line separated by 1/16 in. (1.5 mm) or less edge to edge;
 - Ten or more rounded indications in any 6 sq in. (4000 mm²) of surface with the major dimension of this area not to exceed 6 in. (150 mm) with the Area taken in the most unfavorable location relative to the indications being evaluated.

c) Dimensions check

- (i) The dimensions with specified tolerance shall be measured and verified for components, sub-assemblies and assembly with those mentioned in the approved fabrication drawings including lining material.
- (ii) If the components, sub-assemblies and assembly are not found as per approved fabrication drawings, then faulty components, sub-assemblies and assemblies shall be rejected by IPR.
- (iii) New components, sub-assemblies and assemblies need to be freshly fabricated by vendor if the vendor fails to prove the inspection.

d) Radiography Testing

- (i) Radiography testing for weld joints shall conform to guidance provided in ASME section V_ Subsection A - Article 2.
- (ii) Radiographic film interpretation shall be done by ASNT level II certified personnel.
- (iii) For all thickness X-rays shall be used as source of radiation. Gamma rays shall be employed only when X-rays is not feasible.
- (iv) Procedure for Radiography testing shall be submitted to IPR for review and approval.
- (v) Acceptance criteria:
 - (1) Cracks, Lack of Penetration (LOP), Lack of Fusion (LOF), Oxidation, Undercuts, Linear and angular defects of any type, surface defects in the region of weld and HAZ involving either stress raisers or loss of wall thickness, root concavities shall not be acceptable.
 - (2) Porosity and spherical inclusions in excess of limits stated below:
 - Plate thickness 3mm & less: Defect free weld is required.
 - Plate thickness > 3mm and \leq 6mm: Isolated globular inclusions / porosity permitted provided they are not larger than 0.8 mm diameter in any portion of the weld and do not exceed 4 in number in any length of 300 mm and are separated from each other by at least 4 times their diameter.
 - Plate thickness >6mm and \leq 16mm: Isolated globular inclusions / porosity permitted provided they are not larger than 1.5 mm diameter in any portion of the weld and do not exceed 4 in number in any length of 300 mm and are separated from each other by at least 4 times their diameter.
 - Plate thickness >16mm and < 50mm : Isolated globular inclusions / porosity permitted provided they are not larger than 4 mm diameter in any portion of the weld and do not exceed 4 in number in any length of 300 mm and are separated from each other by at least 4 times their diameter.
 - (3) Indications shown on the radiographs of welds and characterized as imperfections are unacceptable under the following conditions:
 - Any indication characterized as a crack or zone of incomplete fusion or penetration;
 - Any other elongated indication that has a length greater than
 - (i) 1/4 in. (6 mm) for t up to 3/4in. (19 mm), inclusive
 - (ii) 1/3t fort from 3/4in. to 2 & 1/4 in. (19 mm to 57 mm), inclusive
 - (iii) 3/4 in. (19 mm) for t over 2 & 1/4 in. (57 mm)

Where t is the thickness of the thinner portion of the weld

e) Ultrasonic Examination (In lieu of Radiography testing)

- (i) Ultrasonic examination shall be carried in accordance with ASME section V_ Subseciton A - Article 4.
- (ii) The Ultrasonic Examination procedure shall be submitted to IPR for review and approval.
- (iii) Acceptance criteria:

TENDER NO. IPR/TN/PUR/TPT/ET/20-21/10 DATED 31/12/2020

Imperfections which produce a response greater than 20 % of the reference level shall be investigated to the extent that the operator can determine the shape, identity, and location of all such imperfection and evaluate them in terms of the acceptance standards given under (I) below;

- I. Imperfections are unacceptable if the indications exceed the reference level amplitude and lengths exceeding:
 - (i) ¼ in. (6 mm) for t up to ¾ in. (19 mm), inclusive
 - (ii) 1/3rd t for t from ¾ in. (19 mm) to 2 ¼ in. (57 mm), inclusive
 - (iii) ¾ in. (19 mm) for t over 2 ¼ in. (57 mm)

10. Acceptance test

10.1. Factory Acceptance Test (FAT)

- The vendor is responsible for necessary arrangement for inspection and testing during FAT as per respective hold points mentioned in approved Manufacturing and Inspection Plan (MIP).
- The vendor shall submit inspection and testing procedures to IPR for review and approval before starting the FAT.
- The inspection and testing shall be performed are mentioned in the table below;

Phases	Inspection and testing at respective hold points as per approved MIP
01	<p><u>Manufacturing/fabrication stage (Before installation of lining materials);</u></p> <ul style="list-style-type: none"> i. Dimensions of components and/or sub-assemblies of waste feeder chamber and primary chamber assembly including tolerance shall be measured and verified, followed by sub-point (c) of point VIII under section-9, with approved manufacturing/fabrication drawings in respect of drawing numbers IPR/APD/20/A3/CBWTF/A/01, IPR/APD/20/A3/CBWTF/A/03, IPR/APD/20/A3/CBWTF/A/04, IPR/APD/20/A3/CBWTF/B/01, IPR/APD/20/A3/CBWTF/B/02 and IPR/APD/20/A3/CBWTF/B/03. ii. Weld joints inspection to be performed followed by IPR approved NDT methods. The acceptance criteria for Liquid Penetrant Test (LPT)/ Radiography Testing/Ultrasonic Examination are given in point VIII of section-9.
02	<p><u>Lining materials installation stage;</u></p> <ul style="list-style-type: none"> i. Physical verification of purchased lining materials to be done with submitted documents. ii. Dimensions of components and/or sub-assemblies of waste feeder chamber and primary chamber assembly including tolerance after lining application will be measured and verified, followed by sub-point (c) of point VIII under section-9, with approved fabrication drawings including lining materials. iii. Visual inspection of lined materials for any damage, crack, etc. to be performed.
03	<p><u>Installation and erection stage;</u></p> <ul style="list-style-type: none"> i. Overall dimensions of waste feeder chamber and primary chamber assembly along with support structure will be measured including tolerance and verify with those indicated in approved fabrication drawing prepared in respect of drawing number IPR/APD/20/A3/CBWTF/A, IPR/APD/20/A3/CBWTF/B and IPR/APD/20/A3/CBWTF followed by sub-point (c) of point VIII under section-9. ii. Marking for assembly and disassembly of components, sub-assemblies and assembly will be checked.

10.2. Site Acceptance Test (SAT)

- Vendor is responsible for necessary arrangement for inspection and testing during SAT as per respective hold points mentioned in approved Manufacturing and Inspection Plan (MIP).
- The inspection and testing are mentioned in below table;

Sr. no.	Inspection and testing
01	Dimensions including specified tolerance for waste feeder chamber and primary chamber assembly along-with support structures will be measured and verify with those indicated in approved fabrication drawings prepared in respect of drawing number IPR/APD/20/A3/CBWTF/SPSS followed by sub-point (c) of point VIII under section-9.
02	Visual inspection for any damage, crack, etc. in structural components and installed lining materials to be checked followed by sub-point (a) under point VIII of section 9.
03	Marking for assembly and disassembly of components, sub-assemblies and assembly will be checked.

11. Delivery schedule

Phase	Deliverable	Time from acceptance of P.O (T0)
I	Submission of MIP including PERT chart, Quality plan and Support structures & service platforms design and analysis report to IPR	T0 + 04 weeks = T1
II	Review and approval for MIP, Quality plan and Support structures & service platforms design and analysis report by IPR	T2 + 04 weeks = T3
III	Submission of fabrication drawing, Lining material installation procedure and assembly & disassembly procedure to IPR	T3 + 03 weeks = T3
IV	Review and approval of fabrication drawing, Lining material installation procedure and assembly & disassembly procedure by IPR	T3 + 03 weeks = T4
V	Material procurement, inspection, testing and submission of Material Test Certificates, Welding Consumable Test Certificate, Welder qualification and test reports, Material identification and marking Procedure and WPS , PQR , WPQ and Weld Plan to IPR	T4 + 10 week = T5
VI	Approval of Material Test Certificates, Welding Consumable Test Certificate, Welder qualification and test reports, Material identification and marking Procedure and WPS , PQR , WPQ and Weld Plan by IPR	T5 + 04 week = T6

TENDER NO. IPR/TN/PUR/TPT/ET/20-21/10 DATED 31/12/2020

VII	Fabrication and Erection of components/sub-assemblies including lining material installed and completion of Factory Acceptance Test (FAT) as per PO.	T6 + 09 week = T7
VIII	Issuance of dispatch clearance by IPR	T7 + 02 weeks = T8
IX	Delivery and physical verification of items as per PO at FCIPT	T8 + 02 weeks = T9
X	Installation, commissioning and Site acceptance (SAT) test as per PO.	T9 + 04 weeks = T10

12.Document to be submitted

12.1 The following documents shall be submitted to IPR (Total 1 set of soft copy & 2 set of Hard copy) for approval.

1. Support structures and service platforms design and analysis report
2. Manufacturing/Fabrication and updated engineering drawings including lining material installation
3. Quality Plan
4. Manufacturing and Inspection plan
5. Lining material installation procedure
6. Assembly and disassembly Procedure
7. Material Test Certificates
8. Material identification and marking Procedure
9. Welding Consumable Test Certificate
10. Welder qualification and test reports
11. WPS , PQR , WPQ and Weld Plan

12.2 The following documents shall be submitted to IPR (Total 1 sets of soft copy & 2 set of hard copy) before Factory Acceptance Test (FAT).

1. As Built Drawings
2. NDT report
3. Reports on weld repairs and other rectification if any

13.Insurance, packing, handling and Supply

- I. Vendor/Contractor shall pack all the components with the proper material to avoid damages during transportation.
- II. All components shall be cleaned thoroughly with detergent and dried before packing.
- III. Vendor/Contractor shall inform IPR authority before supply of the material to IPR/FCIPT.

14.Guarantee/warranty

Twelve (12) months from date of final acceptance for poor workmanship, welding/fabrication/painting, lining work installation, faulty material, electronics items etc. During this period if any fault occurs/detected in contractor's services, contractor shall rectify the same at no extra cost. In the event contractor fails to fulfil his

SECTION – C

TENDER NO. IPR/TN/PUR/TPT/ET/20-21/10 DATED 31/12/2020

guarantee obligations, IPR shall have the right to remedy or to have remedied the defect/fault, in both cases to contractor's account.

15. Post warranty support

The vendor shall confirm that they will provide the post-warranty support for additional three years after expiry of warranty period i.e. 1 year for any of the mechanical damages or lining material damages in the supplied assembly either at Varansi or Ahemdabad city. However, the cost for such post-warranty support is "**Not To Be Included**" in the quotation against the present tender.

Annexure – I

Please find attached separately engineering drawings of waste feeder chamber and primary chamber assembly (pdf version). The list of attached drawing are mentioned here below;

Sr. no.	Drawing number
01	IPR/APD/20/A3/CBWTF/SPSS
02	IPR/APD/20/A3/CBWTF
03	IPR/APD/20/A3/CBWTF/A
04	IPR/APD/20/A3/CBWTF/A/01
05	IPR/APD/20/A3/CBWTF/A/03
06	IPR/APD/20/A3/CBWTF/A/04
07	IPR/APD/20/A3/CBWTF/B
08	IPR/APD/20/A3/CBWTF/B/01
09	IPR/APD/20/A3/CBWTF/B/02
10	IPR/APD/20/A3/CBWTF/B/03

Annexure – II

LIST OF PREFERRED MAKE

Sr. No.	Item Description	Make/brand
1.	Plate, pipe, forged, rod, etc. of materials as specified in the engineering drawings under Annexure-I.	Tata, SAIL, RINL, Jindal, Fortran Steel Private Limited, Phenix creation simplified or equivalent make/brand.
2.	Structural Rolled Steel sections-beams, channels, tee, flats, angles, bars (round, square, hexagonal) of Mild Steel (M.S.) IS 2062 GRADE E300 Quality A or BR.	Tata, SAIL, RINL, Jindal, Fortran Steel Private Limited, Phenix creation simplified or equivalent make/brand.
3.	Structural Hollow steel sections (Square & Rectangular) and tubular sections of Mild Steel (M.S.) IS 2062 GRADE E300 Quality A or BR.	Tata, Asian, APL Apollo tubes Ltd., Phenix creation simplified, Fortran Steel Private Limited or equivalent make/brand.
4.	Structural tubular sections of Mild Steel (M.S.) IS 2062 GRADE E300 Quality A or BR.	Tata, Asian, APL Apollo tubes Ltd., Phenix creation simplified, Fortran Steel Private Limited or equivalent make/brand.
5.	Refractory layer.	Brick of Calderys, Carborundum Universal Limited

SECTION – C

TENDER NO. IPR/TN/PUR/TPT/ET/20-21/10 DATED 31/12/2020

		(CUMI), MG Materials India, Promat, Mogan Advance materials or equivalent make/brand that conforms to technical specification mentioned under Annexure-III.
6.	Insulation layer type 1.	Brick of Calderys, Carborundum Universal Limited (CUMI), Promat, MG Materials India, Mogan Advance materials or equivalent make/brand that conforms to technical specification mentioned in Annexure-III.
7.	Insulation layer type 2.	Ceramic fiber paper of Mogan Advance materials, Unifrax, Ceramaterials, Calderys, MG Materials India, Carborundum Universal Limited (CUMI) or equivalent make/brand that conforms to technical specification mentioned in Annexure-III.
8.	Welding rod.	Esab India (7018 or 7014) or equivalent.
9.	Construction chemicals (if any).	M.C.Bauchemie, FosrocSika, Cico, Pidilite, Sika, Ashford, BAL, Krishnaconchem or equivalent.
10.	Joint Filler/silicon paint.	Wacker, Dowcorning, Sika, Chokshi or equivalent.
11.	Paint, primer, putty.	Asian, Berger, Nerolac, ICI, Birla (putty) Roofit(Putty) or equivalent.
12.	Polish.	MRF, Asian, ICI, Taralac or equivalent.
13.	Adhesives.	Fevicol, Kitcol, Araldite, BAL or equivalent.
14.	Anchor fastener/bolts.	Sundaram, Hilti.Fischer or equivalent.

Annexure – III

Technical specification for lining materials

I. Refractory layer

Parameters	Properties
Maximum service temperature, (°C)	1600°C - 1850°C
Bulk density, (kg/m ³)	1100 - 1300 kg/m ³
Cold Crushing strength, (kg/cm ²)	≥ 30 kg/cm ²
Thermal conductivity, (W/m-K)	≤ 0.61 W/m-K @ temperature 800°C
Note: Side arc/End arc brick is recommended wherever applicable.	

II. Insulation layer type 1

Parameters	Properties
Classification temperature, (°C)	1250°C - 1550°C
Bulk density, (kg/m ³)	700 - 950 kg/m ³
Cold Crushing strength, (kg/cm ²)	≥ 20 kg/cm ²
Thermal conductivity (W/m-K)	≤ 0.41 W/m-K @ temperature 800°C
Note: Side arc/End arc brick is recommended wherever applicable.	

TENDER NO. IPR/TN/PUR/TPT/ET/20-21/10 DATED 31/12/2020

III. Insulation layer type 2

Parameters	Properties
Classification temperature, (°C)	1250°C - 1550°C
Bulk density, (kg/m ³)	150 - 250 kg/m ³
Tensile strength, (kPa)	≥ 200 kPa
Thermal conductivity, (W/m-K)	≤ 0.10 W/m-K @ temperature 400°C

Annexure – IV**List of spare items**

The vendor shall submit the quote for the following **spares mandatorily in price Bid**. Vendor should also specify the quantity offered. **The quantity mentioned in the price-bid format is tentative.**

Sr. No.	Description	Qty.
1	Refractory layer	200 Nos.
2	Insulation layer type 1	350 Nos.
3	Insulation layer type 2 (Rolls)	01 No.