

INSTITUTE FOR PLASMA RESEARCH

(An Autonomous Institute under Department of Atomic Energy, Government of India)
Near Indira Bridge; Bhat; Gandhinagar-382428; Gujarat; India

Phone: 079-2396-2022/26/27/2332

Fax: 079-23962277

TENDER NOTICE No. IPR/TPT/TN/PUR/F/17-18/31 DATED 27-12-2017

Sealed tenders are invited in **TWO PARTS** from the eligible vendors for the following item/s.

Sr. No	Tender Notice No.	Item	Qty.	Due Date & Time for		Tender Fee	Earnest Money Deposit (EMD)
				Submission of tender	Opening of tender		
1.	IPR/TPT/TN/PUR/F/17-18/31 (TWO PART TENDER)	Design, Manufacturing, Testing & Supply of +35 kV, 100mA Fast Responding High Voltage DC Power Supply as per technical specifications mentioned in our tender documents	1 No.	28th February, 2018 by 13.00 Hrs. I.S.T.	28th February, 2018 by 15.30 Hrs. I.S.T.	Rs. 300.00 or USD 5.00 or EURO 4.00	Rs. 1,00,000.00 or USD 1544.00 or Euro 1295.00

1. For further details, please visit IPR Website : <http://www.ipr.res.in/documents/tenders.html>.
2. Interested parties may download the tender documents & submit their quotation, if they fulfil the eligibility criteria
3. Tender documents will also be issued from this office upto **12-01-2018**. Interested parties may approach us with tender fee.
4. A pre-bid meeting of the tenderers is arranged on **22-01-2018 at 10:00 a.m.** at IPR campus. Tenderers should send their queries, if any (both technical & commercial) together with confirmation of their participation in the pre-bid meeting, at least Seven (7) days prior to the date of Pre-bid meeting.
5. It is to be noted that all further updates or amendments, if any, regarding the tender dates, specifications and terms & conditions shall be notified and uploaded on the IPR website and no separate corrigendum would be published in this regard. Therefore, interested bidders need to visit the website of IPR on a regular basis for such updates.

INSTITUTE FOR PLASMA RESEARCH

(An Autonomous Institute under
Department of Atomic Energy, Government of India)
Near Indira Bridge; Bhat; Gandhinagar-382428; Gujarat; India

Tele No. +91-79-2396-2000

Fax No. 91-79-2396-2277

E-mail : bkbsrao@ipr.res.in, alpesh@ipr.res.in

TWO-PART TENDER

Tender No. IPR/TPT/TN/PUR/F/17-18/31

BID DUE DATE 28th Feb, 2018 @ 13:00 Hrs IST

Date of Opening 28th Feb, 2018 @ 15:30 Hrs IST

M/s _____

Dear Sirs,

Sub: Design, Manufacturing, Testing & Supply of +35 kV, 100mA Fast Responding High Voltage DC Power Supply as per technical specifications mentioned in our tender documents

This document contains Invitation to tender, tendering conditions, contracting conditions and specifications of stores required by us. The tenders in respect of this case are to be submitted in TWO-PARTS. If you are interested to quote, please go through the contents particularly the tendering conditions and ensure that your quotation reaches us on or before the due date indicated above.

Yours faithfully,

BKBS Rao
Purchase Officer-II

INSTITUTE FOR PLASMA RESEARCH

(An Autonomous Institute under
Department of Atomic Energy, Government of India)
Near Indira Bridge; Bhat; Gandhinagar-382428; Gujarat; India
Phone: 079-23962000, Fax: 079-23962277
Email: bkbsrao@ipr.res.in, alpesh@ipr.res.in

Instructions to Tenderers indicating the Tender Number, Last Date and Time for Receipt of Tender, place at which the Tender can be submitted and the Date/Time and Venue in which Tenders will be opened.

Tender No. IPR/TPT/TN/PUR/F/17-18/31 dated 27-12-2017

I	Last Date for reaching both Part - I (Technical & Commercial) and Part - II (Price) of the Tender in Sealed envelopes to Institute for Plasma Research to reach on or before the last date & time.	13:00 Hours (IST) on <u>28th February, 2018</u>
II	Due Date and Time for Opening of Part-I of the Tender i.e. Techno Commercial Part	15:30 Hours (IST) on <u>28th February, 2018</u>
III	Venue for Opening the Tender	Institute for Plasma Research Nr. Indira Bridge Bhat, Gandhinagar-382428 Gujarat

INSTITUTE FOR PLASMA RESEARCH

(An Autonomous Institute under
Department of Atomic Energy, Government of India)
Near Indira Bridge; Bhat; Gandhinagar-382428; Gujarat; India
Phone: 079-23962000, Fax: 079-23962277
Email: bkbsrao@ipr.res.in, alpesh@ipr.res.in

INSTRUCTION SHEET

TENDER NOTICE No. IPR/TPT/TN/PUR/F/17-18/31 DATED 27-12-2017

Design, Manufacturing, Testing & Supply of +35 kV, 100mA Fast Responding High Voltage DC Power Supply as per technical specifications mentioned in our tender documents

1. This is a TWO PART Tender. Bidder should submit the bid in Two Parts,
 - (i) **PART – I** : Technical Bid & Commercial Terms and Conditions **Except price.**
 - (ii) **PART – II** : Price Bid (**Price Alone**)Bidders shall submit the bid in duplicate.
2. **PRICE BID FORMAT** : Bidder shall quote price on the Price Bid Format given in Section-E of tender documents.
3. Full details and specifications of the items and general instructions to be followed regarding submission of tenders are indicated in the tender documents.
4. **Proof for fulfillment of eligibility criteria mentioned above should be submitted along with the tender. If the tender is submitted without valid documents, Purchaser shall not consider your offer. Tenders received without proof of eligibility criteria will be rejected.**
5. While requesting for Tender Documents, such request shall indicate **the “REQUEST FOR TENDER DOCUMENTS AGAINST TENDER NOTICE NO. IPR/TPT/TN/PUR/F/17-18/31 DATED 27-12-2017.”**
6. **Tender Fee: The tender fee (non-refundable) of USD 5.00 (US Dollar Five only) OR EURO 4.00 (EURO Four only) OR Indian Rs. 300.00 (Indian Rupees Three Hundred only) should be made in the form of DEMAND DRAFT drawn in favour of Institute for Plasma Research and payable at Ahmedabad, Gujarat (India). Vendor’s name and tender number shall be indicated on the reverse side of the Demand Draft.**
7. **DD should not be prior dated to the date of advertisement. Separate request letter and separate Demand Draft shall be sent for each tender.**
8. **Those who use the downloaded tender documents from IPR Website may submit the prescribed Tender Fee keeping in a separate envelope along with the tender. This envelope should be marked as “TENDER FEE”.**
9. No request for the extension of due date will be considered.
10. Late/Delayed offers will not be accepted.
11. **Due date for submission of Tender: Tender in a sealed envelope (Part-I, Technical Bid, Commercial Terms & Conditions and Tender Fee & EMD in one envelope and Part-II Price-Bid in another envelope) superscribing the envelope with the above tender no., date, due date and brief description of tendered item**

should be submitted by 13:00 Hrs. I.S.T. on 28th February, 2018 to the Purchase Officer, IPR at the following address

Purchase Officer
Institute for Plasma Research
Near Indira Bridge, Bhat
Gandhinagar – 382428.
Gujarat, INDIA.

Part-I (Techno-Commercial Bid :- Except Price) will be opened on the same day at 15:30 Hrs. I.S.T. in the presence of attending tenderers.

Part-II (Price Bid) : Date of opening of Price Bid of eligible Bidder/s will be intimated to them later on.

12. **Bids received without the prescribed Tender Fee and EMD will be rejected.**
13. The representative who attends the tender opening should carry an authorization letter from the organization for participation in the tender opening failing which he/she may not be allowed to participate in the tender opening. However one representative only will be allowed to participate in the tender opening process.
14. **The tenderers representative, who reaches the venue of tender opening late, i.e. after the starting time specified for opening of the tenders, may not be allowed to take part in the tender opening.**
15. In the event of any date indicated above is declared as a Holiday, the next working day shall become operative for the respective purpose mentioned herein.
16. IPR will not be responsible for any delay/loss of Tender or documents in transit.
17. Bidders should furnish/enclose full technical details/literature, delivery period and confirm the terms and conditions attached with the tender.
18. Bidder will submit technical bid, commercial bid and all supporting documents pertaining to this tender in English.
19. **Specifications :** Technical Specifications & drawings are given in Section-C.
20. **Rejection of bid:**
Non compliance of tender specifications and/or tender documents including terms and conditions will lead to rejection of quotations received.
21. All communications related to this tender must be sent to,

Purchase officer,
Institute for Plasma Research
Near Indira Bridge, Bhat
Gandhinagar – 382428.
Gujarat, INDIA.
Phone: 079 23962022
Fax : 079 23962277
e-mail : bkbsrao@ipr.res.in/alpesh@ipr.res.in/pinto@ipr.res.in
22. **A pre-bid meeting of the tenderers is arranged on 22-01-2018 at 10:00 a.m. at IPR campus. Tenderers should send their queries, if any (both technical & commercial) together with confirmation of their participation in the pre-bid meeting, at least Seven (7) days prior to the date of Pre-bid meeting. Subsequent revision in the technical specification, if any, will be uploaded on our website : <http://www.ipr.res.in/documents/tenders.html>.**
23. The Director, IPR reserves the right to accept or reject any offer in full or part thereof without assigning any reason thereof.

ELIGIBILITY CRITERIA

(The bidder is required to submit all supporting documents as proof for the compliance of the following criteria. The attachments must be serially labelled with the number as given in the table below. Bids received without valid documents and/or incomplete and irrelevant documents are likely to be rejected summarily)

Sr. No	Essential Eligibility compliance	Evidence for submission	Attachment Sr. No. of proofs and evidence
1.	Technical Competence and relevant Experience as on the date of tender notice :- Bidder should have successfully developed and delivered at least one unit of High Voltage DC Power Supply unit (continuous or pulsed) in the range of ~30 kV and above within last five (5) years from the date of tender notice.	Bidder should submit unpriced purchase order with work completion certificate or any other relevant documents conforming the eligibility compliance as a proof of evidence.	
2.	Quality Management :- Bidder should have valid standard quality management certification (s) such as ISO 9001:2008 certification	Bidder should submit valid ISO 9001:2008 certificate or its equivalent.	
3.	Financial Capacity :- Bidder should have average annual turnover during last 3 consecutive financial years starting from Financial Year 2013-2014 of at least INR 1,25,00,000/- or equivalent foreign currency.	Audited balance sheets for the last 3 financial years (2013-2014, 2014-2015 and 2015-2016) to be submitted.	
4.	Single Order Value: - Bidder should have executed single order having value of minimum INR 30,00,000/- or equivalent foreign currency in the field of DC Power Supply System.	Bidder should submit the copies of purchase orders (priced) with completion/installation certificate.	

Note: (1) If, Indian Agent submits offer on behalf their overseas principal/OEM, all documents pertaining to eligibility criteria should be attached of their principal/OEM ONLY.

(2) Original documents shall be produced for verifications, if required.

(3) If quotation is submitted without attaching the documents in support of the eligibility criteria, will summarily be rejected without further communication.

(4) The bidder shall not be under declaration of ineligibility for corrupt or fraudulent practices or blacklisted with any of the Government agencies.

NOTE: Issue of tender documents does not mean that a vendor is qualified to submit tenders. IPR's decision to consider as to whether a vendor has met with the eligibility criteria is final.

TWO PART TENDER

SECTION - A

INVITATION TO TENDER AND TENDERING CONDITIONS

Part I – Techno – Commercial

All commercial & Technical aspects to be given in Part-I

Part – II – Only Price to be given

1.0 INVITATION TO TENDER

1.1 IPR, Invites sealed tenders in duplicate for supply of plant, machinery, equipment, component to the specifications detailed in Section 'C' to this tender document. The conditions of contract which will govern the contract pursuant to the tender are as contained in form no. IPR-FP-12 which is Section 'B' of this tender document. If you are in a position to quote for supply in accordance with the technical specifications indicated in Section 'C' to this tender document and as per conditions in this section and Section 'B' please submit your offer in a manner and method specified below:

1.2 MANNER AND METHOD FOR SUBMISSION OF TENDERS

1.2.1 All tenderers in response to this invitation shall be submitted in Two Parts in ENGLISH as under and in the different envelopes:

1.2.1.1 **Part-I (Techno-Commercial):** This part of the tender shall include/contain all technical details, technical specifications, drawings and also the commercial terms and conditions of contract for the supplies to be made and the services to be rendered EXCLUDING ANY PRICE DETAILS THEREOF.

1.2.1.2 **Part-II (Price):** This part should contain only the prices of the stores offered for supply and the charges for the services to be rendered.

1.2.2 **Part-I (Techno-Commercial)** should contain/include only technical specifications, technical details, literature, reference to earlier supplies of similar equipment without enclosing the purchase order copies, drawings, quantity, time required for submission and approval of drawings, manufacturing and delivery schedule, inspection/testing procedure, itemized list of spares and quantity (without price) recommended by the tenderer for purchase, term of price, mode and terms of payment, mode of despatch, the quantum/percentage of statutory levies payable by the Purchaser as extra and all related commercial terms and conditions for the supplies and for the services like erection and commissioning to be rendered by the tenderers. This part of the tender, i.e. Part-I (Techno-Commercial) shall be enclosed separately in an envelope duly sealed and superscribed with the Purchaser's tender number and the last date and time specified for receipt and opening indicated in the instruction sheet of this tender document. The tenderer shall take special care NOT TO MIX UP the price of the stores in this part of the tender.

1.2.3 **Part-II (Price)** shall include/contain only price, price break-up, freight/safe delivery charges, charges for training of the Purchaser's engineers wherever applicable, lumpsum charges for erection and commissioning work or per diem charges for the supervision of erection and commissioning work as is envisaged in the Purchaser's tender document, testing charges, third party inspection charges

etc. This part of the tender, i.e. Part-II (Price) shall be enclosed separately in an envelope and shall be sent duly sealed and superscribed with the Purchaser's tender number and the last date and time specified for receipt and opening of the tenders as indicated in the instruction sheet of this tender document.

- 1.2.4** The tender will co-relate the prices in Part-II of the tender with the description of the stores indicated in Part-I (Techno-Commercial) by allotting a running serial number in order to enable the Purchaser to identify the prices with the relative items in Part-I (Techno-Commercial).
- 1.2.5 Part-I (Techno-commercial) and Part-II (Price) should be enclosed in a common envelope. This envelope containing both Part-I (Techno-commercial) and Part-II (Price) should again be sealed and superscribed with the Purchaser's tender number and the last date and time specified for receipt and opening indicated in the instruction sheet of this tender document and should reach the Purchase Officer on or before the time and date specified for its receipt. If the tenderer fail or omit to furnish/reach anyone part of the tender, i.e. either Part-I or Part-II within the initial due date and time specified for its receipt in the instruction sheet of this tender document, such tenders will be treated as incomplete and are liable for rejection.
- 1.2.6 If tenderer includes prices of any nature in Part-I (Techno-commercial) of the tender such offers are liable for rejection without any notice to the tenderers.
- 1.2.7 The tenderers shall ensure that the rates quoted by them are given both in figures and words failing which the tenders are liable to be rejected.

1.2.8 LATE/DELAYED TENDERS

- 1.2.8.1 If the envelope containing Part-I (Techno-commercial) and Part-II (Price) does not reach the Purchase Officer, IPR on or before the due date and time specified for its receipt, such tenders will be treated as Delayed/Late tenders and will neither be opened nor considered by the Purchaser and will be summarily rejected. The tenderers should therefore take care and ensure that both Part-I and Part-II of their tenders reach the Purchase Officer, IPR on or before the due date and time specified for their receipt to avoid the rejection of the tenders.

1.3 OPENING OF TENDERS

- 1.3.1 Unless otherwise pre-opened or postponed with advance intimation to the tenderers, tender will be opened in two stages on the date and time indicated in the instructions sheet of this tender document.
- 1.3.2 Part-I (Techno-commercial) of the tender will be opened at the first stage on the due date and time indicated for opening in the instruction sheet of this tender document while the Part-II (Price) will be opened at the second stage after completion of the evaluation of the Techno-Commercial Part (Part-I) of the tender.
- 1.3.3 While all the tenderers who submit tenders within the due date and time specified for its receipt will be permitted to participate in the opening of Part-I (Techno-Commercial) of the tender on the due date and time indicated in the instruction sheet of this tender document, opening of the Part-II (Price) of the tender can be attended to only by such of those tenderers whose Part-II (Price) of the tenders are found to be technical suitable/acceptable to the Purchaser and to whom intimation thereof is given by the Purchaser by Email/letter.
- 1.3.4** The tenderers whose Techno-commercial part (Part-I) are found suitable/acceptable to the Purchaser, will be given seven days advance intimation

by the Purchaser to enable such tenderers to depute their representative to participate in the opening of the Part-II (Price) of the tender. The technically unqualified tenderers will neither be given any intimation about the due date and time of opening of Part-II (Price) of the tender nor will they be permitted to participate in the opening of the same. **Part-II (Price) of the technically disqualified tenderers will not be opened.**

1.3.5 DATE FOR OPENING OF PART-II (PRICE):

After completion of technical evaluation, Part-II (Price) of only technically qualified tenderers shall be opened. The due date and time of opening of Part-II (Price) shall be intimated only to the technically qualified tenderers. Whose Part-I offers have been found suitable will only be permitted to participate in the opening of the Part-II (Price) of the tender.

1.3.6 AUTHORITY LETTER

- 1.3.6.1 The tenderers who wish to participate in the opening of the tenders may depute their representatives to IPR on the respective due date and time as indicated in the instruction sheet of this tender document with an authority letter addressed to the Purchase Officer which should be produced to the officers who are opening the tenders, on demand to prove the bonafide of the representative who participates in the opening of the tender. In case the representative of the tenderer fails to produce such an authority letter on behalf of the tenderer, he will be debarred from participating in the opening of the tenders.
- 1.3.6.2 The tenderers representative, who reaches the venue of the tender opening late, i.e. after the starting time specified for opening of the tenders, may not be allowed to take part in the tender opening. It should be noted that only one representative of each tenderer will be permitted to participate in the tender opening.

1.4 HOLIDAYS

- 1.4.1 If the date (s) specified for receipt and opening of the tenders is/are declared as holidays abruptly by the competent authority due to any administrative reasons, then the due date(s) for receipt/opening of tenders will get postponed automatically to the next working day. As for instance, if the due date for receipt of tender falls on 3rd of a particular month and its opening on 4th day of the month and if the 3rd day of the month is declared as a holiday, then the due date for receipt of tenders will stand automatically postponed to 4th day of the month while its opening will be on the 5th day of the month.

1.5 TECHNICAL CLARIFICATIONS

- 1.5.1 After opening of Part-I (Techno-commercial) of the tender, if it becomes necessary for IPR to seek clarifications from the tenderers, the same will be sought for from the tenderers. In such an event the tenderer shall furnish:
- 1.5.1.1 Any technical and commercial questions, information, clarifications etc. that may be required pertaining to this tender may be obtained from the Purchase officer. Bidder will send the request for such clarifications to the Purchase Officer minimum 10 working days prior to the due date to submit the bid.

1.5.2 Irrespective of the circumstances whether technical clarifications have been sought for or not from any other tenderers, the tenderers will be free to ask technical clarification concerning the scope details of the tender etc. if they so consider it necessary.

1.5.3 Copies of correspondence sent to the Purchase Officer, IPR relating to price and other related commercial terms and conditions should not be endorsed to the technical authorities.

1.6 **VALIDITY OF OFFERS**

1.6.1 Offers shall be kept valid for acceptance for a period of 120 (One Hundred Twenty) days from the date of actual opening of Part-II (Price) of the tender. Offers with shorter validity period will be liable for rejection.

1.7 **CATALOGUES/TECHNICAL LITERATURE**

1.7.1 All necessary catalogues/drawings technical literature data as are considered essential for full and correct evaluation of the offers shall invariably accompany the Part-I (Techno-commercial) of the tender.

1.8 **TERMS AND CONDITIONS OF THE CONTRACT**

1.8.1 It must be clearly understood that any contract concluded pursuant to this invitation to tender shall be governed by the General Conditions of the Contract as contained in form no IPR-FP-12 which is Section 'B' of this tender document. Tenderers must therefore take special care to go through these general conditions of contract and in exceptional cases if any deviations are proposed, these must be clearly indicated in the Part-I (Techno-commercial) of the tender as a separate annexure instead of merely enclosing their printed conditions of sale. Tenders made subject to counter conditions of far too many deviations from the general conditions of contract i.e. Section 'B' of this tender document are liable to be ignored. It should also be realized that failure to bring out deviations from the General Conditions of Contract contained in Section 'B' of this tender document will imply that the tenderer is willing to execute the contract as per the Purchaser's terms and conditions of contract.

1.9 **PRICE**

1.9.1 The prices quoted must be FIRM and preference will be given to such tenders. In exceptional cases (e.g. items involving substantial use of raw materials susceptible to sharp fluctuation in prices) if prices are quoted subject to variation it shall be on the basis of a standard Price Variation Formula. The basis for calculation shall be very clearly stated. Here again preference will be given to the tenders with a specific ceiling on escalation.

1.9.2 Prices quoted shall be in the currency of the country of origin and the offers linking the quoted currency with some other currency are liable to be ignored.

1.9.3 Prices quoted must be on the following basis:

1.9.3.1 F.O.B. / F. C. A. Port of Shipment (i.e. Free on Board the Vessel at the nearest Port of Shipment – packing, inland freight, charges towards loading the consignments on the vessel, documentation etc. included) Name of the Port (Sea/Air) proposed for shipment shall be clearly indicated.

1.10 **SPARES AND ACCESSORIES**

1.10.1 Tenders for Plant /machinery/equipment/component shall also indicate prices for essential accessories, optional accessories and spares necessary for satisfactory operation of the plant/machinery/equipment.

1.10.1.1 For a period of two years and

1.10.1.2 For a period of five years.

1.10.2 Prices for accessories and spares shall be itemized. Tenders where only lumpsum prices are indicated are liable to be ignored. Particular care must be taken to list out each item of spare and quantity recommended and also the individual price for these items. These details should be included only in Part-II (Price) of the tender. However, a list of spares and accessories without the price should be included in Part – I (Techno-commercial) of the tender.

1.11 **QUANTITY**

1.11.1 The Purchaser reserves the right to accept tenders for any quantity of his choice and the tenderers shall be bound to accept a contract for any quantity. The Purchaser also reserves the right to accept or reject lowest or any tender in full or part without assigning any reasons.

1.12 **AUTHORITY OF AGENTS**

1.12.1 In case where a tender is submitted by an Indian Agent on behalf of his foreign principal, such tender should be supported with a 'Letter of Authority' from such Principal that the Indian Agent has been authorized to submit the tender on behalf of the principal. Tenders not accompanied by such a Letter of Authority are liable to be ignored. However, acceptance of offer will be communicated only to the foreign principals directly. The Foreign Principal shall ensure that he submits offer only through one single Indian Agent.

1.13 **AGENCY COMMISSION**

1.13.1 Commission payable to the Tenderer's Agents in India, if any, shall be included in the price. Name and address of the Agents and the percentage of commission payable to them and included in the price shall be clearly indicated. The commission will be paid directly to the Indian Agents in equivalent Indian Currency. The Foreign Principal shall ensure that he submits offers only through one single Indian Agents.

1.14 **STATUS OF INDIVIDUAL SIGNING THE OFFER**

1.14.1 Individuals signing the tender form and other connected documents must specify the capacity in which they sign, like,

1.14.1.1 Whether signing as a 'sole Proprietor' of the firm or his attorney.

1.14.1.2 Whether signing as a 'Partner' of the firm or his attorney.

1.14.1.3 Whether signing for the firm 'As Agent'

1.15 **TRAINING**

1.15.1 The contractor shall, in special cases, if required by IPR, provide facilities for the practical training of the Purchaser's engineers and technical personnel from India

and for their active employment process of plant/machinery/equipment/instrument through the manufacturing period of the contract/stores. Such training would normally be required only in case of special plant/machinery/equipment/instrument and particularly manufactured equipment. In such an event, the Purchaser shall bear travelling and billeting expenses of the trainees and the contractor will be required only to bear the cost of the training program. Wherever, himself would recommend such training, he should furnish the cost of such training and indicates clearly the number of trainees and the duration of the training that he would recommend.

1.16 SUBMISSION OF DRAWINGS

1.16.1 The tenderer shall furnish all drawings pertaining to the plant/machinery/equipment/component to the Purchaser along with the tender for correct understanding and appreciation of the tender in duplicate. Besides, tenderers should also furnish general arrangement, schematic and such other drawings prescribed by the Purchaser within 4 weeks from the date of receipt of a Purchase Order for approval. Such drawing should be furnished along with Part – I (Techno-Commercial) of the tender. Tenderer's drawing will form part of the Purchase Order/Contract only after these are approved by the Purchaser.

1.17 SUB-CONTRACTING/SUBLETTING

1.17.1 The tenderer in the event of his tender being accepted by the Purchaser shall not assign/sublet or delegate the contract or any part thereof without the prior written consent of the Purchaser which consent shall not be unreasonably withheld, but the tenderer may without the Purchaser's consent purchase such parts, accessories, raw materials, etc. from any of the leading and reputed manufacturers in case he does not normally manufacture such items. However the contractor shall be solely responsible for the satisfactory execution of the contract irrespective of the fact whether a part or a portion of a contract has been assigned or sublet by him to a sub-contractor even when such sub-contracting has been done with the prior written consent of the Purchaser.

1.18 SHOP / FACTORY EVALUATION, QUALITY SURVEILLANCE/ INSPECTION AND SUBMISSION OF PROGRESS REPORTS.

1.18.1 The Purchaser or his technical authorities may at his option and prior evaluation of the tender depute his inspector or any quality surveillance of his choice to the factory/workshop of the tenderer to assess and establish the manufacturing Capability etc., of the tenderer. Similarly, the Purchaser may also depute his Inspector/Quality Surveillance agency of his choice for inspection of the plant/machinery/equipment/component during the various stages of manufacture. In such an event the tenderer/contractor shall

1.18.1.1 Allow reasonable facility and free access to his factory/works/records to the Inspector for the purpose of inspection or for ascertaining the progress of manufacture and delivery.

1.18.1.2 Provide the drawings, tooling, gauges, instruments etc. required for carrying out the inspection work.

1.18.1.3 Produce an inspection plan to the Purchaser's satisfaction notifying him when checkpoints on the plan are imminent.

- 1.18.1.4 Not supply or deliver the plant/equipment/machinery/component unless and until a Shipping Release or an authorization for despatch is obtained in a format provided by the Purchaser. Failure to comply with this instruction will not only result in with holding of the payment to the contractor/supplier but also hold the tenderer/contractor liable for payment of compensation to the Purchaser due to delay in clearance of the equipment/plant/machinery/component from the carriers.

1.19 ERECTION AND COMMISSIONING

- 1.19.1 Tenderers must clearly and separately furnish in their offers the terms of supervision of erection and commissioning particularly in respect of plant/machinery/equipment.

- 1.19.2 In respect of Contractors involving installation and commissioning by the overseas supplier where identifiably charges for the same has been quoted by the tenderer, he shall bear the income tax liability as per the rates prevailing at the time of undertaking the job in accordance with the income tax act in force in India, as specified in clause No. 6 of additional tendering condition.

1.20 INSTRUCTION MANUAL

- 1.20.1 In respect of plant/machinery/equipment/instruments/apparatus, where instruction/ operation manual is normally necessary to enable the user to put the plant/machinery/equipment/instrument/apparatus to proper use, the Contractor shall furnish such an instruction/operation manual specific to the stores being supplied along with the plant/machinery/equipment /instrument/ apparatus. The Contractor shall clearly specify in the offer about his readiness to supply instruction/operation manual.

1.21 PACKING

- 1.21.1 Tenderers shall note that packing for shipment shall be in accordance with the instructions outlined in this tender document and each package shall be limited to the size and weights that are permissible under the existing Air and Sea limitations. Even when no packing specification is included in the invitation to tender, it will be Supplier's responsibility to provide appropriate packing depending upon the nature of the supply and the transportation and handling hazards.

- 1.21.2 The equipment shall be so packed and protected as not to suffer deterioration damage or breakage during shipment and storage in a tropical climate.

- 1.21.3 Each package shall be properly labelled to indicate the type and quantity of material it contains, the purchase order number, its dimensions and weight and any other necessary data to identify the equipment and relate it to contract.

1.22 DEVIATIONS TO PURCHASER'S SPECIFICATIONS AND CONDITIONS OF CONTRACT

- 1.22.1 If any deviation or substitution from the technical specifications contained in Section "C" to this tender document is involved, such details should be clearly indicated in Part-I (Techno-Commercial) and should be added as an annexure to Part-I (Techno-commercial) of the tender as otherwise it shall be an admission on the part of the tenderer that he will supply the equipment as specified by the Purchaser. Similarly, deviations to the Purchaser's General Conditions of Contract/Special Conditions of

Contract contained in Section “B” of this tender document shall be indicated by the tenderer in another annexure to Part-I (Techno-commercial) of the tenderer.

1.22.2 Part-II (Price) should be furnished in accordance with the format provided by the Purchaser at Section “E” of this tender document.

1.23 DELIVERY

1.23.1 Tenderers should strictly adhere to the delivery schedule mentioned in the offer.

1.24 ACCEPTANCE OF TENDERS

1.24.1 Acceptance of tenders by the Purchaser will be sent by fax, E-mail, letter etc. within the validity of the tender and such a fax, email, letter etc. would then be followed by a formal purchase order/contract. The tenderer whose offer is accepted will proceed with the execution of the contract on the basis of such advance acceptance of tenders without waiting for a formal purchase order/contract and will be responsible to seek and obtain whatever clarifications that are necessary from the Purchaser to proceed with the manufacture without waiting for a formal purchase order/contract and delivery period will be reckoned from the date of the Letter/ /Fax of Intent.

1.25 RESULT OF THE TENDERS

1.25.1 Unsuccessful tenderers will not be informed of the result of their tenders.

1.26 SETTLEMENT OF COMMERCIAL TERMS AND CONDITIONS OF CONTRACT

1.26.1 In case the commercial terms and conditions of sale/contract stipulated in Part - I (Techno-commercial) of the tender submitted by the tenderer are at variance with the Purchaser’s General Conditions of all Contracts/Special Conditions of Contract stipulated in Section “B” of this tender document, the Purchase Officer will settle the commercial terms and conditions of contract with the tenderers chosen for award of the contract by holding discussions with them OR by sending Fax/Letter/E-mail etc. In case the concerned tenderer to whom an intimation thereof is given does not respond/fail to respond to communication sent by the Purchaser within the date specified, his tender is liable for rejection and no complaints whatsoever will be entertained from the tenderer for rejection of this tender. The tenderers should not discuss with the technical authorities/user department any of the commercial terms and conditions of contract and any agreement/understanding reached between the tenderer and the technical authorities will not be valid and binding.

1.27 OFFERS BY FAX, TELEX, CABLE, TELEGRAM & E-MAIL

1.27.1 Offers sent/submitted by fax, telex, cable, telegram and e-mail will not be considered at all and are liable for rejection without any notice to the Tenderers.

ADDITIONAL TENDERING CONDITIONS.

1. Installation and commissioning

a) Wherever, the purchaser's invitation to tender calls for installation and commissioning or supervision of installation and commissioning of the instrument/equipment by the tenderer, the tenderer must clearly and separately quote the prices for the supply of the stores and the charges and the terms for installation and commissioning or supervision of installation and commissioning, as the case may be. The charges towards installation and commissioning should not be included in the price of the stores.

- b) In respect of contracts involving installation and commissioning by the overseas supplier where identifiable charges for the same has been quoted by the tenderer, he shall bear the Income-tax liability as per the rates prevailing at the time of undertaking the job in accordance with the Income-tax Act in force in India, as specified in Clause No. 6 below.
- c) When the scope of the contract includes installation and commissioning, it shall be the sole responsibility of the contractor to undertake the installation and commissioning as and when called for, by the purchaser.

2. Performance Bank Guarantee:

- 2.1 In the event of acceptance of the offer in respect of plant, machinery, equipment, instrument, etc. the tenderer will be required to submit a performance bank guarantee for 10% of the total value of the contract from SBI/any nationalized bank or private sector banks, namely, ICICI Bank, IDBI Bank, HDFC Bank and AXIS Bank, on a non-judicial stamp paper of appropriate value valid till 2 months beyond the expiry date of warranty period as per the Purchaser's format towards satisfactory performance of the plant, machinery, equipment, instrument, etc. during the warranty period. In case of bids in currency other than INR performance bank guarantee shall be furnished from any bank of international repute.
- 2.2 In case of non-submission of performance bank guarantee by the Contractor, an amount equivalent to 10% of the total value of the stores and other charges admitted in the contract will be retained by the purchaser till the expiry of the warranty period of the stores.
- 2.3 Offers of the tenders who are not agreeable to furnish performance bank guarantee or retaining of an equivalent amount by the purchaser as per clause No. 2.1 and 2.2 above, are likely to be rejected.

3. STATUTORY LEVIES SUCH A GOODS & SERVICE TAX, IMPORT CUSTOMS DUTY

3.1 CUSTOMS DUTY

- 3.1.1 The purchaser is entitled for assessment of Customs Duty at the concessional rate of 5% as per Amendment No. 24/2002-Custom dt. 1.3.2002 to Customs Notification No.51/96-Custom dt. 23.7.1996, issued by the Department of Revenue, Ministry of Finance in respect of purchases made for the Research Institutions under the Department of Atomic Energy, and the purchaser will obtain and provide the requisite certificate from the appropriate authority for availing of the concessional rate of custom duty.
- 3.1.2 In case an Indian supplier/agent submits an offer for supply of out rightly imported stores in Indian Rupees, they should quote the price for sale on High-Seas, i.e. CIF Port of Destination (like CIF Ahmedabad). However, the transit insurance for the same should be taken from an Indian Insurance company nominated by the purchaser, so as to provide insurance coverage from anywhere in the world to anywhere in India. The Custom Clearance of the consignment in such cases will be arranged by the purchaser.
- 3.1.3 Wherever, against a requirement, both indigenious as well as imported offers are received, the offers for imported stores will be evaluated on the basis of the total landed cost after loading the custom duty and other levies as may be applicable from time to time for taking purchase decision.

3.1.4 Customs Duty exemption certificate will not be issued for raw materials/components or any other intermediary materials going into the manufacture of the end product.

3.2 **GOODS AND SERVICE TAX**

GOODS AND SERVICE TAX where legally leviable will be admitted and reimbursed at the rate applicable during original delivery period.

When GOODS AND SERVICE TAX is claimed as extra by the vendor in general, the following certificates should be submitted by the vendor to the Paying Authority on the bills itself :-

Certified that the GOODS AND SERVICE TAX charged has not been exempted under the GST Act or the rules made thereunder and the amount charged on account of GST are not more than what is payable under the provision of relevant ACT or the rules thereunder.

Certified further that we are being assessed to GST and also that where there are statutory exemptions under the Relevant Act/Law of the State Government concerned, we have availed ourselves of it and certified non-availability of such a provision for GST wherever claimed. Certified further in respect of amount claimed into the bill no claim is pending for refund/or admissible. Certified that in the event of our getting refund in whole or in part of the element of GOODS AND SERVICES TAX claimed from Government, we shall pass on the benefit to the Purchaser by remitting to Government the amount equivalent to the amount of refund obtained by us.

Certified further that we (our Branch or agent) _____ (address) are registered in the state of _____ under GST Regn. No. _____.

(Stamp & Signature of the Vendor)

The vendor shall solely be responsible for declaration of Goods and Service Tax made in his invoice and shall indemnify the purchaser from any claim or its liability from concerned authorities at any stage.

Certificate with each bill to the effect that no refund has been obtained in respect of the reimbursement of GST made to vendor during three months immediately preceding the date of the claim covered by the relevant bill.

AN UNDERTAKING to the effect that in case any refund of GST is granted to the vendor by concerned authorities in respect of stores supplied under the contract, they shall pass on the credit to the purchaser immediately alongwith a certificate from their Director/Manager/ Proprietor/Accountant to the effect that the credit so passed on relates to the GST originally paid for the stores supplied under the contract. In case of their failure to do so within 10 days of the issue of the refund orders to them by the Authorities, the purchaser would be empowered to deduct a sum equivalent to the amount refunded by the authorities without any further reference to the vendor, from any of their outstanding bills against this or any other pending Government Contracts and that no dispute on this account would be raised by the vendor.

Vendor should provide GSTIN Certificate alongwith HSN code of the tendered item alongwith their quotation.

IPR is entitled to avail tax benefit as per the following notifications:

a) GST for Goods (IGST/CGST/SGST TAX BENEFITS): Notifications issued by Ministry of Finance, Department of Revenue, Government of India:

(1) No: 47/2017-INTEGRATED TAX (RATE) DATED 14/11/17 for IGST

(2) No: 45/2017-CENTRAL TAX (RATE) DATED 14/11/17 for CGST

And,

Notification issued by Finance Department, Government of Gujarat:

(1) No. 45/2017-STATE TAX (RATE) DATED 15/11/17 for SGST

As per above notifications IPR will bear only 5% IGST for procurement of goods from outside Gujarat & 2.5% CGST and 2.5% SGST (total 5%) for procurement of goods within Gujarat. Vendors are required to charge tax as per these notifications while quoting/supplying the goods. Deviations, (if any) should be clearly mentioned in the quotation/offer. Please specify the HSN codes while quoting.

b) GST for Services:

As applicable. Specify the SAC codes wherever services are involved. 16.4 DEDUCTION OF TAX AT SOURCE (TDS)

4. PURCHASE PREFERENCE

In respect of offers from Central Public Sector Enterprises, they will be eligible for purchase preference, if any, when they compete with the Private Sector Units as per the policy of the Government of India in force at the time of evaluation provided their offer is technically suitable.

5. PRICE PREFERENCE FOR MICRO & SMALL ENTERPRISES

In respect of offers from SSI units and Micro & Small Enterprises (MSEs) registered with appropriate Government authorities will be eligible for price preference, as admissible as per the policy of Government of India provided their offer is technically suitable.

6. Deduction of Tax at Source (TDS):

As per Government of India rules, it is mandatory that income tax shall be deducted at source at applicable rates as per relevant act, rules and notifications issued by the government from time to time.

- 1) **In case of Indigenous Vendors** (Indian Suppliers who provide indigenous products and services, Indian subsidiaries with permanent establishment in India who supply imported goods and services and paid in Indian currency only): Tax deducted at source will be applicable under Section 194-C for carrying out any work (including supply of labour for carrying out any work) in pursuance of contract as per Income Tax Act 1961. In case of technical or professional services, TDS will be applicable as per under Section 194-J of Income Tax Act 1961.
- 2) **In case of Foreign Vendors** (Foreign Suppliers who provide goods from abroad paid in foreign currency and providing technical services by Indian subsidiary paid in Indian currency): The TDS is applicable where services are rendered in India directly or through their Indian counter part against foreign Purchase order / Contract as per the provision of under Section 195 of Income Tax act of India. Wherever DTAA (Double Taxation Avoidance Agreement) agreement exists between India and the supplier country the provisions

of the agreement shall be applicable. For getting benefit of DTAA (Double Taxation Avoidance Agreement), the following documents must be submitted, otherwise full TDS will be deducted.

- a) No Permanent Establishment in India certificate
- b) Tax Residency Certificate (TRC) issued by Tax authorities of their country
- c) Form 10F if TRC does not contain required details
- d) PAN (Permanent Account Number) details issued by Indian Income Tax Authority

Important Note:

- a) Where bifurcation is inappropriate and unacceptable for supply of material and providing services the purchase order / contract will be treated as **Composite Contract** and TDS will be deducted on whole contract / purchase order value as per applicable rate.
- b) TDS or any other leviable taxes or duties, if applicable, shall be deducted recovered from the Supplier's bill and necessary certificate will be issued to the supplier.
- c) Details on relevant sections of Income Tax Act and DTAA treaties can be obtained from <https://www.incometaxindia.gov.in/Pages/acts/income-tax-act.aspx>.

7. Offers from Indian Agents on behalf of foreign suppliers:

In case the tender is submitted by an Indian supplier/Indian agent on behalf of their foreign supplier/ principals, following documents should be submitted with the tender, failing which, their offer is liable to be ignored.

- a. Photocopy of the Agency Agreement between the Principals and the Indian Agent showing the percentage or the quantum of agency commission payable and a Letter of Authority from the Principals authorizing the Indian Agents to submit the tender on their behalf.
- b. The type and nature of after sales services to be rendered by the Indian Agent.
- c. Both Indian Agent or Principal/OEM can not bid simultaneously for the same item /product in the same tender.
- d. The Indian Agents are allowed to quote on behalf of only one foreign Principal/ Supplier against this tender.
- e. Copy of Registration Certificate with DGS&D or DPS.

8. Security Deposit Bank Guarantee:

In the event of acceptance of an offer, the tenderer will be required to submit a security deposit for 10% of the value of the contract/order in the form of Bank Guarantee valid till atleast 2 months beyond the contractual date of completion of the order/contract. The bank guarantee should be executed by SBI/any nationalised bank or private sector banks, namely, ICICI bank, IDBI bank, HDFC bank or AXIS bank or any international reputed bank, on the requisite Non-judicial Stamp Paper of appropriate value, as per the purchaser's format. In case of bids in currency other than INR, bank guarantee shall be furnished from any bank of international repute.

Offers wherein tenderers declined to submit Security Deposit are liable to be rejected.

9. Conditional Discount:

In case the tenderer offers any conditional discount with regard to acceptance of their offer within a specific period or for the specific payment terms, delivery, quantity etc. the

purchaser will not take into consideration such conditional discount while evaluating their offer.

10. Past Performance:

In case the past performance of the tenderer is not found to be satisfactory with regard to quality, delivery, warranty obligation and non-fulfilment of terms and conditions of the contract, their offer is liable to be rejected by the purchaser.

11. Capacity & Financial Standing:

In case it is found that the tenderer does not possess the requisite infrastructure, capacity, capability and their financial standing is not satisfactory, such tender is liable to be rejected by the purchaser.

12. EXPORT LICENCE / EXPORT PERMISSION:

It is entirely the responsibility of the suppliers who are quoting for materials of foreign origin to ensure obtaining export permission/licence/authorisation as required from the respective Government before arranging shipment. This Department would not accept post supply inspection by any agency/authority of any foreign country. It is, therefore, necessary that the vendors offering materials from foreign countries shall have thorough knowledge of export contract regulations in vogue in those countries. The vendors shall indemnify the purchaser against any consequences in respect of any end-use declaration they/their overseas Principals may furnish to the government/government agencies of the country of origin of the materials, while seeking export permission/licence. Post supply inspection, contrary to the terms and conditions of purchaser's contract shall be deemed to be null and void. This Department reserves the right to reject any offer, which is not in conformity with the above instructions.

Whenever an End-use Certificate is desired by the contractor, the same shall be clearly mentioned in the offer and the purchaser shall provide an End-user Certificate as per the format given below. The Purchaser will not provide any other document/declaration in this regard.

END USER STATEMENT:

We hereby certify that the item/s i.e.....being procured from
M/s.....
against our Purchase Order No. IPR/.....dated.....
will be used for.....

We also certify that the item/s will not be used in designing, developing, fabricating or testing of any chemical, biological, nuclear, or weapons of mass destruction or activities related to it.

It is further certified that we will not re-export the Item/s prior to obtaining permission from the concerned authorities as may be required".

13. Country of Origin:

Wherever the tenders are for imported stores, the Country of Origin of the stores must be clearly specified in the offer.

14. Confidentiality:

The drawings, specifications, prototypes, samples or any other correspondence/details /information provided by the Purchaser relating to the tender or the contract shall be kept

confidential by the Contractor, and should not be disclosed or passed on to any other person/firm without the prior written consent of the Purchaser. This clause shall apply to the sub-contractors, consultants, advisers or the employees engaged by the contractor.

15. Compliance with the Security Requirements of the Purchaser:

The Contractor shall strictly comply with the Security Rules and Regulations of the Purchaser in force and shall complete the required formalities including verification from Police and any other authority and obtain necessary prior permission for entry into the Purchasers premises, wherever authorised by the Purchaser.

16. Rates to be Quoted in Figures & Words:

The tenderers shall ensure that the rates quoted by them are given both in **figures and words** failing which the tenders are liable to be rejected.

17. Permanent Account Number (PAN) :

Tenderers are required to submit a true copy of the PAN Card/Letter and copy of the factory Registration/Licence or shop establishment certificate as applicable with the quotation, failing which the tenders are liable to be rejected.

18. FREE ISSUE MATERIAL: *(This clause shall apply only to contracts for supply of fabricated equipment with purchaser's Free Issue Materials (FIM)).*

Wherever contracts envisage supply of Free Issue Material (FIM) by the Purchaser to the contractor for fabrication of the contracted equipment/stores, such Free Issue Material shall be safeguarded by an insurance policy to be provided by the Contractor at his own cost for the full value of such materials and the insurance policy shall cover, the following risks specifically and shall be valid for six months beyond the contractual delivery date:

1. **RISKS TO BE COVERED:** Any loss or damage to the Purchaser's materials due to fire, theft, riot, burglary, strike, civil commotion, terrorist act, natural calamities etc. and any loss or damage arising out of any other causes such as other materials falling on purchaser's materials.

2. **INSURED BY :** (Name of the Contractor)

3. **BENEFICIARY :** Institute for Plasma Research
Nr. Indira Bridge
Bhat, Gandhinagar-382428
Gujarat
INDIA

4. **AMOUNT FOR WHICH INSURANCE POLICY TO BE FURNISHED.** The amount will be indicated in the respective Contract.

Free Issue Material (FIM) will be issued to the Contractor only after receipt of the Insurance Policy from the Contractor. The contractor shall arrange collection of the FIM from the Purchaser's premises and safe transportation of the same to his premises at his risk and cost.

Notwithstanding the insurance cover taken out by the Contractor as above, the Contractor shall indemnify the Purchaser and keep the Purchaser indemnified to the extent of the value of free issue materials to be issued till such time the entire contract is executed and

proper account for the free issue materials is rendered and the left over/surplus and scrap items are returned to the Purchaser. The contractor shall not utilize the Purchaser's free issue materials for any job other than the one contracted out in this case and also not indulge in any act, commission or negligence which will cause/result in any loss/damage to the Purchaser and in which case, the Contractor shall be liable to the Purchaser to pay compensation to the full extent of damage/loss. The Contractor, shall be responsible for the safety of the free issue materials after these are received by them and all through the period during which the materials remain in their possession/control/custody. The free issue materials on receipt at the Contractor's works shall be inspected by them for ensuring safe and correct receipt of the material. The Contractor shall report the discrepancies, if any, to the Purchaser within 5 days from the date of receipt of the material. The Contractor shall take all necessary precautions against any loss, deterioration, damage or destruction of the FIMs from whatever cause arising whilst the said materials remain in their possession/custody or control. The free issue materials shall be inspected periodically at regular intervals by the Contractor for ensuring safe preservation and storage. The Contractor, shall also not mix up the materials in question with any other goods and shall render true and proper account of the materials actually used and return balance remaining unused material on hand and scrap along with the final product and if it is not possible within a period of one month from the date of delivery of the final product covered by this purchase order. The Contractor, shall also indemnify the Purchaser to compensate the difference in cost between the actual cost of the free issue material lost/damaged and the claim settled to the Purchaser by the insurance company. The decision of the Director, IPR, as to whether the Contractor has caused any loss, destruction, damage or deterioration of the free issue materials while in his possession, custody or control from whatever cause arising and also on the quantum of damage suffered by the government, shall be final and binding upon the Contractor

19. RESTRICTED INFORMATION CATEGORIES UNDER SECTION 18 OF THE ATOMIC ENERGY ACT, 1962 AND OFFICIAL SECRETS UNDER SECTION 5 OF THE OFFICIAL SECRETS ACT, 1923

Any contravention of the above mentioned provisions by the contractor, sub-contractor, consultant, adviser or the employees of the contractor will invite penal consequences under the aforesaid legislation.

20. PROHIBITION AGAINST USE OF THE NAME OF ANY INSTITUTION OF DEPARTMENT OF ATOMIC ENERGY WITHOUT PERMISSION FOR PUBLICITY PURPOSES

The Contractor or sub-contractor, consultant, adviser or the employees engaged by the contractor shall not use the name of any Institution of Department of Atomic Energy for any publicity purpose through any public media like Press, Radio, TV or Internet without the prior written approval of the Purchaser.

21. LIABILITY

Tenderers shall be liable for any damage to the purchaser or any third party out of any patent or latent defect in the goods supplied by him or sub-standard services rendered by him.

22. PURCHASER'S RIGHT

The Purchaser shall be under no obligation to accept the lowest or any other tender and shall be entitled to accept or reject any tender in part or full without assigning any reasons whatsoever.

23. FLUCTUATION IN THE EXCISE DUTY/CUSTOMS DUTY

Unless otherwise specifically agreed to in terms of the Contract, the purchaser shall not be liable for any claim on account of fresh imposition and /or increase in Excise Duty, Customs Duty and Sales Tax on raw materials and/or components used directly in the manufacture of the contracted stores, taking place during the pendency of the contract.

24. EARNEST MONEY DEPOSIT (EMD)

Bid must be submitted along with interest free Earnest Money Deposit (EMD) for USD 1,544.00 (US Dollars One Thousand Five Hundred Forty Four only) OR EURO 1,295.00 (EURO One Thousand Two Hundred Ninety Five only) OR Indian Rs. 1,00,000.00 (Rupees One Lakhs only) by way of Demand Draft drawn in favour of **Institute for Plasma Research payable at Ahmedabad, Gujarat, INDIA.** EMD of unsuccessful bidder(s) will be returned after finalization of the contract. The successful Tenderers EMD shall be discharged upon the Bidder submitting the Security Deposit as specified in the contract/purchase order, without any interest.

24.1 The Tender Fee/EMD in case of INR shall be from State Bank of India (SBI)/any Nationalized Bank or any one of the Banks mentioned in bracket (ICICI, IDBI, HDFC, AXIS) or any international reputed bank.

24.2 In case the Tender Fee/EMD is from any foreign Bank, it should be from a first class bank of international repute.

Exemption from payment of EMD: The firms registered with DGS&D, NSIC, DPS or Micro & Small Enterprises (MSEs) which are actual producers/manufacturers of tendered items are exempted from payment of EMD provided valid registration certificate is uploaded along with the offer. In the case of foreign bidders, payment of EMD is exempted if they submit their bid directly or through their Indian agent in **foreign currency** against the tender document bought by them, so that the order can be placed directly on their Principals.

The EMD may be forfeited:

- i. If a Tenderer withdraws or amends or modifies or impairs or derogates its bid during the period of bid validity specified by the Bidder on the Bid Form; or
- ii. In case of a successful tenderer, if the tenderer fails to furnish order acceptance within 15 days of the order or fails to submit the Security Deposit within 21 days from the date of contract/order.

25. SAMPLES/PROTOTYPES

If any called for shall be submitted free of all charges by the Tenderer and the Purchaser shall not be responsible for any loss or damage thereof for any reason whatsoever. In the event of non acceptance of the tender, the tenderer will have to make arrangements to remove/collect the sample/prototypes at his own expenses.

GENERAL CONDITIONS OF CONTRACT

Form No IPR-FP-12

GENERAL CONDITIONS OF CONTRACT
APPLICABLE TO **PURCHASE ORDER / CONTRACTS** FOR IMPORTED STORES
PLACED BY THE INSTITUTE FOR PLASMA RESEARCH

SECTION – 1**1. PEAMBLE**

1.1 While the conditions contained in Section I will apply to all contracts. Section II will also apply to contracts for Plant/Machinery/Equipment/Instrument.

2.0 GENERAL CONDITIONS OF CONTRACT**2.1 DEFINITIONS AND INTERPRETATION**

2.1.1 In the contract and the general and special conditions governing it, unless the context otherwise requires

2.1.2 “PURCHASER” means the shall mean the Institute for Plasma Research, acting through the Director or his authorized representative [herein after called as “IPR”]

2.1.3 “DIRECTOR”, means the Director of IPR, for the time being in the administrative charge of the Director, IPR and includes the Senior Purchase Officer, Purchase Officer or Assistant Purchase officer or any other officer authorized for the time being to execute contracts relating to the purchase and supplies of stores on behalf of the Purchaser.

2.1.4 “CONTRACTOR” or “SUPPLIER” means the individual firm or company with whom or with which the contract/purchase order for supply of Stores is placed and shall be deemed to include his successors, heirs, executors, administrators and permitted assignees, as the case may be.

2.1.5 “CONTRACT” or “PURCHASE ORDER” means and comprises of a Letter or *Cable or *Telex or *Fax(*followed by a written confirmation) conveying acceptance of Contractor’s offer and invitation to tender, tender containing offer, advance acceptance of the offer, acceptance of offer, general and special conditions of contract specified in the acceptance of offer and any subsequent amendments/alterations thereto made on the basis of mutual agreement.

2.1.6 “STORES” OR “MATERIAL” means the goods specified in the contract/purchase order which the contractor has agreed to supply under the contract.

2.1.7 “SUB-CONTRACTOR” or “SUB-SUPPLIER” means any contractor or supplier engaged by the contractor or the supplier with the prior approval of the Purchaser in relation to the contract/purchase order.

2.1.8 “INSPECTOR” or “QUALITY SURVEYOR” means any Engineer nominated and deputed by the purchaser or their appointed Consultants or quality Surveillance Agency or any other person from time to time authorized by the Purchaser to act as his representative for the purpose of inspection of stores under the contract/purchase order.

2.1.9 PARTIES

2.1.9.1 The parties to the contract are the Contractor and the Purchaser and the Purchaser named in the Contract/Purchase Order.

2.2 **AUTHORITY OF PERSON SIGNING THE CONTRACT ON BEHALF OF THE CONTRACTOR**

2.2.1 The person signing the contract or the purchase order or any other document in respect of the contract or purchase order on behalf of the contractor shall be deemed to warrant that he has the authority to bind the contractor

2.3 **SUB-CONTRACTING**

2.3.1 The contractor/supplier shall not assign, sublet or delegate the contract or any part thereof without the Purchaser's prior written consent, which consent shall not be unreasonably withheld, but he may without the Purchaser's consent purchase such parts, accessories or associated equipment as he does not normally manufacture.

2.4 **DRAWINGS AND SPECIFICATIONS**

2.4.1 The drawings and specifications are intended to be complementary and to provide for and comprise everything necessary for the completion of supply. Any material shown on the drawing even if not particularly described in specifications or vice versa is to be supplied by the Contractor as if it were both shown and specified.

2.4.2 Should any discrepancy be noted in the drawings and/or specifications and should any interpretation of the same be required, the matter shall be referred to the Purchaser for clarification which shall be binding upon the contractor. Otherwise, the contractor shall assume responsibility for the interpretation of the drawings and specifications including interpretation by his sub-contractors.

2.4.3 Should any difference or dispute arise with regard to the true intent and meaning of drawings or specification or should any portion of the same be obscure or capable of more than one interpretation, the same shall be decided by the Purchaser whose decision shall be final.

2.4.4 All lettering on the drawings is to be considered as part of the specification and contract. In all cases figured dimensions are to be followed rather than those indicated by scale. Large scale drawings will take precedence over smaller scale drawings.

2.4.5 The contractor's drawings shall, when approved by the Purchaser, be deemed to be included in the list of drawings which form part of the contract. The contractor shall not proceed with fabrication until all drawings associated therewith have been duly approved by the Purchaser.

2.4.6 The Contractor shall be responsible for and shall pay for any alterations of the stores and shall indemnify the Purchaser for any consequential expenditure incurred by the Purchaser due to any discrepancies, errors, omissions in the drawings or other particulars supplied by him whether such drawings or specifications have been approved by the Purchaser or not, provided that such discrepancies, errors or omissions be not due to inaccurate information or specifications furnished to the contractor on behalf of the Purchaser.

2.5 **GENERAL WARRANTY**

2.5.1 The stores supplied by the contractor under the contract shall be of best quality and workmanship. The contractor shall supply the stores in accordance with the contract specifications unless any deviation has been expressly specified in the contract and any amendments agreed thereto.

2.5.2 The contractor's offer to supply stores in accordance with the tender specifications shall be deemed to be in admission on his part that he has fully acquainted himself with the details thereof and no claim shall lie against the Purchaser on the ground that the contractor did not examine or acquaint himself fully with the tender specifications.

2.6 **ALTERATIONS**

2.6.1 The Purchaser may, from time to time, make changes in the drawings specifications and issue additional instructions without altering the purchase order in any manner provided that no changes shall have been ordered which materially alter the character and scope of the supply under the contract.

2.6.2 It shall be lawful for the parties to the contract to alter by mutual consent at any time and from time to time the drawings and specifications and as from the dates specified by him stores to be supplied shall be in accordance with such altered drawings and specifications provided that if any such alterations involve increase or decrease in the cost of or in the period required for production, a revision of the contract price and/or the period prescribed for delivery shall be made by mutual agreement in respect of the stores to which the alteration applies. In all other respects, the contract shall remain unaltered.

2.7 **PACKING**

2.7.1 The contract shall pack the stores at his own cost sufficiently and properly for transit by sea/air as the case may be so as to ensure their being free from loss or damage while in transit to the ultimate destination specified in the contract.

2.7.2 Unless otherwise provided in the contract all containers (including packing cases, boxes, tins, drums and wrappings) in which the Stores are supplied by the contractor shall be considered as property of the Purchaser and their cost as having been included in the contract price.

2.8 **INSPECTION**

2.8.1 The contractor shall be responsible for and perform all inspection and testing required in accordance with the contract/purchase order and specifications included therewith.

2.8.2 The Purchaser may at his option depute his representative for Inspection of the stores to be supplied under the contract or authorize and nominate a Quality Surveillance Agency of his choice for the purpose hereinafter called, in either case, the inspection.

2.8.3 The supplier shall give notice of readiness for inspection to the Inspector (deputed under clause 2.8.2 above) so that the Inspector can be present at the requisite time. In such an event delivery shall not be effected until an authorization or shipping release is obtained from the Purchaser's Inspector.

2.8.4 The contractor shall allow reasonable facility and free access to his work/factory and records to the inspector for the purpose of inspection or for ascertaining the progress of delivery under the contract.

2.9 **MARKING**

2.9.1 Each package delivered under the contract shall be marked by the contractor at his own expense on three sides of the package and such markings shall be distinct and shall clearly indicate the description and quantity of stores, name and address of the consignee, gross and net weight of the package, name of the contractor, ultimate destination, port of discharge etc.

The marking shall generally be as under

Name and address of the consignee	Purchase Officer, Institute for Plasma Research, Nr. Indira Bridge Bhat, Gandhinagar-382428 Gujarat, India.
Contract Number and Date	No. _____ Date _____
Brief Description of Goods	
Weight	
Dimension	
Ultimate Destination	
Port of Discharge	
Package Number	

2.9.2 Each package shall contain a packing note specifying the name and address of the contractor, the number and date of the contract/purchase order, name and address of the consignee, description of the stores and the quantity contained in such package.

2.9.3 The inspector, wherever deputed by Purchase under clause 2.8.2 may reject the stores of the stores are not packed and/or Marked as aforesaid and in case where the packing materials are specifically prescribed, if such materials are not in accordance with the terms of the contract.

2.10 **TIME FOR AND DATE OF DELIVERY – THE ESSENCE OF CONTRACT.**

2.10.1 The time for and date of delivery of the stores stipulated in the contract shall be deemed to be of the essence of the contract and delivery must be completed not later than date/dates stipulated.

2.10.2 **EXTENSION OF DELIVERY SCHEDULE / LIQUIDATED DAMAGES**

2.10.2.1 If any delay in delivery shall have arisen from any cause such as strike, lockouts, fire, accidents, riot or the like which the purchaser may admit as reasonable ground for grant of extension of delivery schedule, the purchaser will allow such additional period for the purpose as he may consider necessary taking the circumstances into consideration.

2.10.2.2 If the contractor fails to deliver the stores or any instalment or part thereof within the period fixed for such delivery or such additional period allowed by the purchaser in accordance with foregoing para or any time before the expiry of such period repudiates the contract, the Director, IPR may without prejudice to the rights of the purchaser.

2.10.2.2.1 recover from the contractors as agreed liquidated damages and not by way of penalty a sum equivalent to 2% (two percent) of the price of any stores which the contractor has failed to deliver within the period fixed for delivery in the contract or such additional period as mentioned in para 2.10.2.1 for each month or part of the month during which the delivery of such stores, may be in arrears where delivery thereof is accepted after expiry of the aforesaid period. (For the purpose of computing the damages for delayed supplies under the clause, the cost of the entire plant/machinery/equipment/instrument will be taken into consideration if the plant/machinery/equipment/instrument cannot be put to the intended use for want of delayed portion of supply). OR

2.10.2.2.1.1 To recover from the Contractor, at the sole discretion of the Purchaser, token liquidated damages up to 10% of the normal liquidated damages may be imposed.

2.10.2.2.1.2 **Conditions under which Liquidated Damages will be levied are** as under:

CONDITION	LEVY OF LIQUIDATED DAMAGES
i) Delay in supplies resulted in monetary loss actual/demonstrable and supplier was fully responsible for the delay	Full Liquidated Damages will be levied as specified.
ii) Delay in supplies resulted in monetary loss actual/demonstrable but the supplier was responsible only for part of the delay and remaining part of the delay was beyond their control and attributable to the purchaser.	Full Liquidated Damages will be levied as specified for which supplier is responsible.
iii) Delay in supplies resulted in monetary loss actual/demonstrable and entire delay was due to circumstances beyond their control and fully attributable to the Purchaser	Liquidated Damages may be waived in full.
iv) Delay in supplies. However, monetary loss actual/ demonstrable cannot be certified	Token Liquidated Damages equal of 10% of full Liquidated Damages will be levied.

2.10.2.2.2 Purchase or authorise the purchase elsewhere without notice to the contractor, on the account and at the risk of the contractor of the stores not so delivered or others of a similar description (where stores exactly complying with the contract specification are not in the opinion of the Director, IPR whose opinion shall be final, readily procurable) without cancelling the contract in respect of the portion instrument not yet due of delivery. OR

2.10.2.2.3 Cancel the contract or portion thereof and if so desired purchase or authorise purchase of the stores not so delivered or others of a similar description (where stores exactly complying with the contract specification are not in the opinion of the Director, IPR whose opinion shall be final, readily procurable) at the risk and cost of the contractor, if the contractor had defaulted in the performance of the original contract, the purchaser shall have

the right to ignore his offer in response to risk purchase enquiry even though the lowest.

- 2.10.3 Where action is taken under sub-clause 2.10.2.2.2 or sub-clause 2.10.2.2.3 above the contractor shall be liable for any loss which the purchaser may sustain on that account provided the purchaser or, if there is an agreement to purchase such agreement is made, in case of failure to deliver the stores within the period fixed for such delivery within six months from the date of such failure and in case of repudiation of the contract before the expiry of the aforesaid period of delivery, shall not be entitled to any gain on such purchase and the manner and method of such purchase shall be in the entire discretion of the Director, IPR. It shall not be necessary for the purchaser to serve a notice of such purchase on the contractor.
- 2.10.4 **Extension of time:** As soon as it is apparent that contract dates cannot be adhered to an application shall be sent by the contractor to the Purchaser. If failure, on the part of the Contractor to deliver the stores in proper time shall have arisen from any causes which the Purchaser may admit as reasonable ground for an extension of time (and his decision shall be final) he may allow such additional time as he considers it to be justified by circumstances of the case without prejudice to the Purchaser's rights to cover liquidated damages under clause 2.21.2 hereof
- 2.10.5 However, if the contractor fails to apply and secure extension of contract delivery dates before effecting the delivery of the supplies against the contract, acceptance of such stores by the Purchaser will in no way prejudice the rights of the Purchaser to levy the liquidated damages for delayed deliveries nor will it entitle the contractor for payment of statutory levies that come into force after the expiry of the contract delivery dates.

2.11 **RECTIFICATION AND REPLACEMENT OF DEFECTIVE STORES**

- 2.11.1 If the inspector find that the contractor has executed any unsound or imperfect work, the inspector shall notify such defects to the contractor and the contractor on receiving the details of such defects or deficiency, shall at his own expenses, within seven days or otherwise within such time as may be mutually agreed upon as reasonably necessary, proceed to alter, reconstruct or remanufacture the stores to the requisite standard and specifications as called for by the tender specification.

2.12 **INSPECTOR'S AUTHORITY TO CERTIFY PERFORMANCE**

- 2.12.1 The Inspector, where ever deputed by the Purchaser under Clause 2.8.2 shall have the power:
- 2.12.1.1 Before any stores or parts thereof submitted for inspection to certify that they cannot be in accordance with the contract owing to the adoption of any unsatisfactory method of manufacture.
- 2.12.1.2 Reject any stores submitted for inspection or part thereof as not being in accordance within the specification.

2.13 **CONSEQUENCE OF REJECTION**

- 2.13.1 If on the store being rejected by the inspector or consignee at the destination the contractor fails to make satisfactory supplies within the stipulated period of delivery, the Director, IPR may:

- 2.13.1.1 Allow the contractor to submit for inspection fresh stores in replacement of those rejected, within specified time, the contractor bearing the cost of freight on such replacement without being entitled to any extra payment on that account. OR
- 2.13.1.2 purchase or authorise the purchase of quantity of the stores rejected or others of similar description (where stores exactly complying with the contract specification are not in the opinion of the Director, IPR which opinion shall be final, readily available) without notice to the contractor at his risk and cost and without affecting the contractor's liability as regards further supply of stores due under the contract.
- 2.13.1.3 Cancel the contract and purchase or authorise the purchase of stores or others of a similar description (where stores exactly complying with the contract specification are not in the opinion of the Director, IPR which opinion shall be final, readily available) at the risk and cost of the contractor. In the event of action being taken under sub clause 2.13.1.2 above of this sub-clause, the provision of Clause 2.10.2 shall apply as far as applicable.

2.14 **WARRANTY**

- 2.14.1 The contractor warrants that stores to be supplied under the contract shall be free from all defects and faults in materials, workmanship and manufacture and shall be of the highest grade and consistent with the established and generally accepted standards for stores of the types under the contract in full conformity with the specifications, drawings or samples, if any and shall if operable, operate properly. This warranty shall expire (except in respect of complaints notified to the contractor prior to such date) twelve months after the date of receipt of the last lot of stores under the contract at the ultimate destination stipulated in the contract.
- 2.14.2 Should any defect or deficiency in the stores supplied by the contractor under the contract appear to be discovered within 12 months from the date of receipt of the stores in India, the contractor upon notification of such defects or deficiency by Purchaser, shall forthwith take measure to rectify every such defect, deficiency or failure without cost to the Purchaser. If the contractor after such notification shall make default or delay in diligently rectifying all such defects, deficiencies or failure to the satisfaction of the Purchaser, the Purchaser may take recourse to the remedies provided for in clause 2.10.2.2.2 as applicable.

2.15 **PERMIT AND LICENCES**

- 2.15.1 The contractor shall secure and pay for all licences and permit at his end which he may be required to comply with all laws ordinances and regulations of the public authorities in connection with the performance of his obligations under the contract. The contractor shall be responsible for all damages and shall indemnify and save the purchaser harmless from against all claims for damages and liability which may arise out of the failure of the contractors to secure and pay for any such licences and permits or to comply fully which any and all applicable laws ordinances and regulations.

2.16 **PATENT INDEMNIFICATION**

- 2.16.1 The Contractor shall indemnify and keep indemnified the Purchaser from and against any and all claims, actions, costs, charges and expenses arising from or for infringement of patent rights, copy right or other protected rights, of any design plans, diagrams, drawings in respect of the stores supplied by the contractors or any of the manufacturing methods or process adopted by contractor for the stores supplied under the contract.

2.16.2 In the event of any claim being made or action being taken against the purchaser in respect of the matter referred to clause 2.16.1 above, the contractor shall promptly be notified thereof and he shall at his own expense, conduct all negotiations for the settlement of the same and any litigation that may arise therefrom.

2.16.3 In the event of any designs, drawing, plans or diagrams or any manufacturing methods or process furnished by the contractor constituting infringement of patent or any other protected rights and use thereof is restrained, the contractor shall procure for Purchaser, at not cost to the letter, the rights to continue using the same or to the extend it is possible to replace the same so as to avoid such infringement and subject to approval by the Purchaser or modify them so that they become noninfringing, but such modifications shall otherwise be to the entire satisfaction of the Purchaser.

2.16.4 The provision of the clause remain effective and binding upon the Contractor even after the completion, expiration or termination of the contract.

2.17 **MODE AND TERMS OF PAYMENT**

2.17.1 Unless otherwise specified in the contract, payment in full (excluding the amount of the commission included in the price payable directly by the Purchaser to the Indian Agent) shall be made within thirty (30) days from the date of presentation of the following documents to the Purchaser's Bank specified in each contract:

- a. Negotiable Bill of Lading or Airway Bill as the case may be evidencing shipment
- b. Invoice for the shipment : Four Copies
- c. Packing List : Four copies
- d. Certificate of country of origin : Two copies
- e. Shipping release from Inspector or Quality Surveillance Agency nominated by the Purchaser for the purpose of inspection: Four copies
- f. Certificate of Quality including work test certificates of Chemical Analysis where applicable: Two copies
- g. Shipping authorization from purchaser wherever required.
- h. Bank Guarantee for the 10 percent of the value of contract in respect of plant/machinery/equipment/instrument towards performance bond as provided for in Clause 2.22.8 of Section II

An advance copy of invoice along with details of documents forwarded through bank should be sent to the Paying Authority mentioned in the Purchase Order to enable him to verify the claim and honour the documents is in order without delay.

2.17.2 The contractor shall be responsible to make available to the purchaser the documents which are essential for arranging customs clearance in India. The contractor shall arrange through his bank to have the documents air mailed to the Purchase's bank without any delay. He shall also arrange to forward directly to the Purchase Officer, IPR, three copies of non-negotiable Bill of lading or Airway Bill as the case may be, along with a copy of the invoice and packing list. If the purchaser incurs any extra expenditure by way of penalty payable to the Port Trust authorities in India or any other such expenditure due to delay in receipt of shipping documents specified by him, the contractor shall be responsible for making good such extra expenditure incurred by the Purchaser.

2.17.3 **BANK CHARGES**

2.17.3.1 While the Purchaser shall bear the bank charges payable to his Bankers in India (State Bank of India, Ahmedabad) the Contractor shall bear all the bank charges

payable outside India including the charges towards advising/amendments commission.

2.17.4 AGENCY COMMISSION

2.17.4.1 The amount of commission included in the price and payable to the Indian Agents of the Contractor shall be paid directly to the Indian Agents by the Purchaser in equivalent Indian Rupees on the basis of an Invoice from the Indian Agent. "Payment will be released to the Indian Agents after receipt and final acceptance of the goods by the Purchaser and the exchange rate will be the one based on which payment is made to the Contractor".

2.17.4.2 The contractor shall send invoice only for the net amount payable to him after deducting the amount of agency commission included in the invoice which would be paid to the Indian Agents directly by the Purchaser. However the contractors invoice should separately reflect the amount of commission payable to his Indian Agent.

2.18 INSURANCE

2.18.1 Transit insurance from warehouse to warehouse shall be arranged by the purchaser through his underwriters unless this responsibility is specifically entrusted to the contractor in any particular case.

2.19 WITH-HOLDING AND LIEN IN RESPECT OF SUMS CLAIMED

2.19.1 Whenever any claim or claims for payment of a sum of money arises out of or under the contract against the contractor, Purchaser shall be entitled to withhold and have a lien to retain to the extent of the such claimed amount, from any sum or sums found payable or which at any time thereafter may become payable to the contractor under the same contract or any other contract with the Purchaser or any person contracting through the Director, IPR pending finalisation of any such claims.

2.19.2 It is an agreed term of the contract that the sum of money or money so withheld or retained under the lien referred to above by the purchaser will be kept withheld or retained as such by the purchaser till the claim arising out of or under the contract is determined by the Arbitrator and that the contractor will have no claim for interest or damage whatsoever on any contract in respect of such with-holding or retention under the lien referred to supra and duly notified as such to the contractor.

2.20 LIEN IN RESPECT OF CLAIMS IN OTHER CONTRACTS

2.20.1 Any sum of money due and payable to the Contractor (including the security deposit returnable to him) under contract may be withheld or retained by way of lien by the Purchaser or any other person or persons contracting through the Director, IPR against any claim of the Purchaser or such other person or persons in respect of payment of a sum of money arising out of or under any other contract made by the contractor with the Purchaser or with other such person or persons.

2.20.2 It is an agreed term of the contract that the sum of money so withheld or retained under this clause by the Purchaser will be kept withheld or retained as such by Purchaser till this claim arising out of in the same contract or any other contract is either mutually settled or determined by the arbitrator, and that the contractor shall have no claim for interest or damages whatsoever on this account or on any other ground in respect of any sum of money with-held or retained under this clause and duly notified as such to the contractor.

2.21 ARBITRATION

2.21.1 All disputes arising in connection with the present contract shall be finally settled under the Rules of Conciliation and Arbitration of the International Chamber of Commerce by one or more Arbitrators appointed in accordance with the said Rules.

2.21.2 LIQUIDATED DAMAGES

2.21.2.1 As per Standard Terms & conditions, the Purchaser reserves the right to levy the Liquidated Damages, for delay in supply beyond the contractual delivery date at the rate of 2% of the value of the stores the delivery of which is delayed, for each month or part of a month.

SECTION II

In addition to the General Conditions of Contract contained in Section I above the following Special conditions shall apply to contracts for supply of plant/machinery/equipment/manufactured equipment. These special conditions in Section II shall override the latter.

2.22 SPECIAL CONDITIONS OF CONTRACT

2.22.1 RESPONSIBILITY FOR COMPLETENESS

2.22.1.1 All fittings or accessories which may not be specifically mentioned in the tender specifications of the contract but which are necessary, are to be provided by the contractor without extra charge and the plant/machinery/equipment/instruments must be completed in all respect.

2.22.2 FINAL TEST

2.22.2.1 The final tests as to performance and guarantee shall commence within one month of completion of successful installation.

2.22.3 REJECTION OF DEFECTIVE PLANT

2.22.3.1 If the completed plant or any portion thereof before it is finally accepted is found to be defective or fails to fulfil the requirements of the contract, the Purchaser shall give the Contractor notice setting forth with the details of such defects or failure and the contractor shall forthwith rectify the defective plant or alter the same to make comply with the requirement of the contract. Should the contractors fail to do so within a reasonable time the Purchaser may reject and replace at the cost of the Contractor, the whole or any portion of the Plant as the case may be, which is defective or fails to fulfil the requirement of the contract. Such replacement shall be carried out by the Purchaser within a reasonable time and at reasonable price and where reasonably possible to the same specifications and under competitive conditions. The Contractor shall be liable to pay to the Purchaser the extra cost, if any, of such replacement delivered and or erected as provided for in the contract such extra cost being the difference between the price paid by the Purchaser under the provisions above mentioned for such replacement and the contract price for them. Contractor shall refund to Purchaser any sum paid by the Purchaser to the Contractor in respect of such defective plant.

2.22.4 WARRANTY

2.22.4.1 At least for a period of twelve calendar months after the plant/machinery/equipment/instruments has been put into operation (or a suitable mutually agreed longer period to be reckoned from the date of last major shipment depending upon the nature of the plant/machinery/equipment/instrument) the Contractor shall be responsible for any defects that may develop under conditions provided for the contract and under proper use, arising from the faulty materials, design or workmanship in the plant or from faulty erection of the plant by the Contractor, but otherwise and shall rectify such defects at his own cost when called upon to do so by the Purchaser who shall state in writing such defects.

2.22.4.2 If it becomes necessary for the Contractor to replace or renew any defective portions of the plant for purpose of rectification under this clause, the provisions of this clause shall apply to the portions of the plant so replaced or renewed under the expiration of six months from the date of such replacement or renewal or until the end of the above mentioned period of twelve months whichever may be the later. If any defects not rectified within reasonable time, the purchaser may proceed to get the work done at contractor's risk and expenses but without prejudice to any other rights which the Purchaser may have against the Contractor in respect of such defects.

2.22.4.3 All inspections adjustments, replacements or renewals carried out by the Contractor during the warranty period shall be subject to the same conditions as in the contract.

2.22.5 All contractor shall under that before going out of production of the spare parts he will give adequate advance notice to the Purchaser so that the letter may order his requirement of spares in one lot if he so desires.

2.22.6 The contractor shall further guarantee that if he goes out of production of spare parts, then he will make available blue prints, drawings of spare parts and specifications of material at no cost to the Purchaser, if and when required in connection with the equipment to enable Purchaser to fabricate or procure spare parts from other sources.

2.22.7 The provision of this clause shall remain effective and binding upon the Contractor even after the completion or expiration of the contract and till the plant/machinery/equipment supplied under the contract is in use by the Purchaser.

2.22.8 ERECTION AND COMMISSIONING

2.22.8.1 In all cases where contracts provide for supervision of erection and commissioning or for test at the Purchaser's premises the Purchaser except where otherwise specified, shall provide free of charge, such labour, Materials, fuels, stores, apparatus and instruments as may be required from time to time and as may reasonably be demanded by the contractor to carryout efficiently such supervision of erection and commissioning and for the requisite test. In case of contracts requiring electricity for the completion of erection, commissioning and testing at site, such electricity shall be supplied free to the Contractor.

2.22.8.2 Action by the Purchaser under the clause shall not relieve the contractor of his warranty obligation under the contract.

2.22.9 TRAINING

2.22.7.1 The Contractor shall, if required by the Purchase, provide facilities for the practical training of purchaser's engineering or technical personnel from India and for their

active association on the manufacturing process throughout the manufacturing period of the contract/stores, number of such personnel to be mutually agreed upon.

2.22.10 **PERFORMANCE BOND**

2.22.10 The Contractor shall furnish a performance bond in the form of a bank guarantee as per the specimen at Appendix "A" to this section for an amount equal to ten percent (10%) of the total value of the contract valid till expiration of the warranty period as a security for the satisfactory performance of the plant/machinery/equipment/instrument supplied under the contract.

2.22.11 **MODE OF PAYMENT**

2.22.11.1 Unless otherwise agreed to in writing between the Purchaser and the Contractor, payment for the delivery of the material will be made as follows.

(1) Through Letter of Credit :-

The Letter of Credit will be established for 80% of FCA/FOB value after receipt of valid export license by the vendor (if required) and will be allowed to draw payment as under:-

80% of the FCA/FOB value will be paid against presentation of clear & unconditional shipping documents together with the shipment clearance letter issued by IPR to the negotiating Bank.

(2) Through Wire Transfer :-

20% of the FCA/FOB value plus Installation & Commissioning (if applicable) will be paid within 30 days after installation and commissioning and completion of satisfactory acceptance tests at IPR site and on submission of the Invoice with Final Acceptance Certificate issued by IPR & alongwith 10% Performance Bank guarantee of the contract value from a first class foreign bank/nationalized/scheduled bank, valid throughout the warranty period and the grace period of 2 months. ***(A format for performance bank guarantee is attached herewith (refer appendix 'A')).***

2.22.11.2 **Advance payments, if any, will be loaded with interest @ 12% p.a. upto the delivery period quoted for the purpose of comparison of price amongst the bidders.**

Interest for delay in supply beyond the contractual delivery date: Wherever advance payments are sought for by the contractor and admitted in the contract, against Bank Guarantee for equivalent amount, in the event of any delay in supply beyond the contractual delivery date for reasons attributable to the contractor, interest charges @ 12% shall be levied for the period beyond the contractual delivery date, on the amount of balance advance payment to be adjusted.

APPENDIX 'A'

TO

PORTION II, SECTION B SPECIAL CONDITIONS OF CONTRACT PERFORMANCE BOND

(TO BE EXECUTED BY THE CONTRACTOR'S BANK **On non-judicial stamp paper of appropriate value**)

Institute for Plasma Research
Nr. Indira Bridge
Bhat, Gandhinagar-382428
Gujarat
INDIA

WEHREAS on or about the _____ day of _____ 200____ M/s. _____ having its registered Office at _____ (hereinafter called 'The Contractor') entered into an Agreement No. _____ dated _____ for manufacture and supply of _____ hereinafter called 'The Contract') with the Director, IPR (hereinafter called 'The Purchaser')

AND WHEREAS under the terms and conditions of the contract final payment amounting to --under the contract is to be made against a performance bond in the form of bank guarantee furnished by the Contractor for a sum _____ of equivalent to 10% (Ten per cent) of the value of the contract towards satisfactory performance of the _____ (hereinafter called the equipment) valid for a period of 12 months from the date of putting into operation of the said equipment or _____ months from the date of receipt of the last lot of consignment whichever is earlier.

NOW We, (bank) in consideration of the promises and payment of the final/balance amount of _____ under the contract to the contractor hereby agree and undertake to pay on demand and without any demur to the Director, IPR of the contractor a sum not exceeding _____ against any loss or damage that may be suffered by the Purchaser by the reasons of any unsatisfactory performance of the said equipment.

AND we, _____ (Bank) hereby also agree that the decision of the said Director, IPR as to whether the said equipment is giving satisfactory performance or not and as to the amount of loss or damages suffered by the Purchaser on account of unsatisfactory performance of the said equipment shall be final and binding on us.

AND We (bank) hereby further agree that our liability hereunder shall not be discharged by virtue of any agreement between the Purchaser & the Contractor whether with or without knowledge and/or consent or by reason of the Purchaser showing any indulgence or forbearance to the contractor whether as to payment, time performance or any other matter whatsoever relating to the contract which but for this provision would amount to discharge of the surety under the law.

Our guarantee shall remain in force until _____ and unless a claim under the guarantee is lodged with us within six months from the date (i.e. _____), all rights of the Purchaser under the Guarantee shall be forfeited and we shall be relieved and discharged from all our liabilities hereunder.

Our liability under this guarantee shall not be affected by any change in our constitution or the constitution of the contractor.

(Stamp & Signature)
FOR AND ON BEHALF _____ (BANK)
DATED AT _____ THE _____ 200

APPENDIX 'B'

TO

PORTION II, SECTION B SPECIAL CONDITIONS OF CONTRACT SECURITY DEPOSIT

(TO BE EXECUTED BY THE CONTRACTOR'S BANK - **On non-judicial stamp paper of appropriate value**)

THIS DEED OF GUARANTEE MADE AT _____ this ____ day of _____ between _____ having its registered office at _____ and one of its branches at _____ (hereinafter called "the Bank" which expression shall mean and include the said _____ and its successors and assigns) of the one part AND IPR (INSTITUTE FOR PLASMA RESEARCH) Near Indira Bridge, Bhat, Gandhinagar 382 428, Gujarat, India (hereinafter called "the purchaser" which expression shall mean and include the said INSTITUTE FOR PLASMA RESEARCH, ANDHINAGAR and its successors and assigns) of the other part.

WHEREAS _____ (hereinafter called "the Contractor/Supplier") having its registered office at _____ have entered into a Contract having order/contract value of Rs./USD/Euro _____ (Rupees/USD/Euro _____) with the purchaser being _____ Purchase order/Contract No. _____ Dated _____ for _____ in accordance with the terms, specifications and conditions contained therein.

AND WHEREAS under the terms of the aforesaid order/contract, the contractor/Supplier is to furnish to the Purchaser a Bank guarantee for an amount of Rs./USD/Euro _____ (Rupees/USD/Euro _____) being 10% of the total value of the purchase order/contract by way of security for fulfilment of the Contractual obligations on the part of the Contractor/Supplier thereunder.

AND WHEREAS the Contractor/Supplier has requested the Bank to guarantee the due payment of the aforesaid amount by the contractor/supplier to the purchaser in case the contractor/supplier fails to fulfil any of the aforesaid contractual obligations.

NOW THIS DEED WITNESSES AS FOLLOWS:

1. The Bank hereby agrees unequivocally and unconditionally to pay within 48 hours, on demand, in writing from the purchaser or any officer authorised by it in this behalf and without demur, any amount upto and not exceeding Rs./USD/Euro _____ (Rupees/USD/Euro _____) to the Purchaser on behalf of the Contractor /Supplier.
2. This guarantee is valid and binding upon the Bank till final acceptance of the ordered item/s by the Purchaser and fulfilment of all the contractual obligations to the satisfaction of the Purchaser and shall not be terminable or affected by notice of any change in this constitution of the Bank or of the firm of Contractor or on account of any reason whatsoever.
3. The liability of the Bank hereunder shall not be impaired or discharged by any extension of time or variations or alterations made or conceded or agreed within or without the knowledge or consent of the Bank or by or between the parties to the said Purchase order.
4. The liability of the Bank under this deed is restricted to the sum of Rs./USD/Euro _____ (Rupees/USD/Euro _____) and same shall remain in force till final acceptance of the ordered item/s covered in the Purchase order (two months beyond final acceptance date). In case any further extension of the present guarantee is required the same shall be granted on receiving instructions in writing there for from the contractor/supplier on whose behalf this guarantee is issued.
5. Unless proceeding for enforcing this guarantee is commenced against the Bank

within two months from the expiry of the aforesaid period or such extended period or period as aforesaid all the rights of the Purchaser under this guarantee shall be extinguished and the Bank shall be relieved and discharged from all liabilities hereunder.

6. The neglect or forbearance of the Purchaser in enforcement of any of its rights under the aforesaid purchase order against the contractor/supplier shall in no way relieve the Bank of its liability under this deed.

In witness whereof, we the _____ have executed this. This the _____ day of _____ 20_____.

Witnesses: (1)

(2)

SECTION - C

TECHNICAL SPECIFICATIONS OF STORES AND DRAWINGS.

Technical Specifications for DESIGN, MANUFACTURING, TESTING & SUPPLY OF +35 Kv, 100mA FAST RESPONDING HIGH VOLTAGE DC POWER SUPPLY

Title	Design, Manufacturing, Testing, Supply and Commissioning of High Voltage DC Power Supply(+35kV, 100mA)
Sub Title	Scope of Supply, Scope of Work, Technical and Management Specifications

Institute for Plasma Research

Bhat, Gandhinagar-382428



Table of Contents

1	Introduction	41
2	Scope of Supply	41
3	Scope of Work	41
4	Technical Specifications	41
4.1	<i>Input Side Specifications</i>	41
4.2	<i>Output Side Specifications</i>	41
4.3	<i>Control requirements at Front Panel</i>	42
4.4	<i>Control Requirements at Remote Side</i>	42
4.5	<i>Display/Indications on Front Panel Side</i>	42
4.6	<i>Measurements, Metering and Monitoring Requirements at Front Side/Local</i>	43
4.7	<i>Protections, Alarm and Terminations</i>	43
4.8	<i>Load Specifications:</i>	43
4.9	<i>Desired Requirements</i>	44
4.10	<i>Typical Expected Waveforms</i>	45
5	Conceptual Technical Proposal	45
6	Engineering Design Report	45
7	Acceptance Tests	45
7.1	<i>Factory Acceptance Tests (FAT)</i>	45
7.2	<i>Site Acceptance Tests (SAT)</i>	45
8	Management Specifications	46
8.1	<i>Project Execution Schedule</i>	46
8.2	<i>Quality Plan</i>	46
8.3	<i>Factory Acceptance tests (FAT)</i>	46
8.4	<i>Operating and Instruction Manual</i>	46
8.5	<i>Material Dispatch/Packaging and Delivery</i>	46
8.6	<i>Site Acceptance tests (SAT)</i>	47
8.7	<i>Final Acceptance</i>	47
8.8	<i>Warranty</i>	47
9	Annexures	48
9.1	<i>Application Description</i>	48
9.2	<i>Guidelines</i>	51
9.3	<i>Operation and Instruction Manual</i>	53

List of Tables

Table 1 Technical Specifications of BPS unit.44
Table 2 Project Execution Schedule.....46

List of Figures

Figure 1 Representation of Output Voltage's Resolution and Ripple.....45
Figure 2 Electrical Circuit arrangement of the Gyrotron Tube.....48
Figure 3 Equivalent load circuit for Body Power Supply Unit.....48
Figure 4 Timing Definitions & required Waveforms of BPS Unit with RC Load49
Figure 5 Control Interface of BPS Unit50
Figure 6 Operation diagram of the BPS Unit.....50

1 Introduction

Institute for Plasma Research (IPR), Gandhinagar is mainly involved in research and development activities related to Plasma Science and Technologies (www.ipr.res.in). Institute for Plasma Research (IPR) intends to procure a continuous duty high voltage power supply (called hereafter as “Body Power Supply- BPS”). This tender deal with, design, manufacturing, testing, supply and commissioning (at site) of fast responding BPS (High Voltage DC Power Supply) at IPR Campus in Gandhinagar.

2 Scope of Supply

Design, manufacturing, testing, supply and acceptance tests at site of BPS (High Voltage DC Power Supply) at IPR Campus in Gandhinagar, with load bank including all accessories and documentation.

3 Scope of Work

The scope of work includes, but not limited to, the following main tasks:

- i. Design of high voltage power supply as per technical specifications specified in Section: 4.
- ii. Submission of detailed design documents including Quality plan as mentioned in Section: 6 for IPR’s review and approval. Material procurement, Fabrication and assembly of the unit as per functional requirements.
- iii. Arrange the stage wise inspections as per agreed Quality Plan and implementation of modifications (if any)
- iv. Perform the Factory Acceptance Tests (FAT) as per approved acceptance test procedure complying the specifications as specified in Section: 7.1.
- v. Upon receipt of dispatch clearance note from IPR; Pack and Deliver the power supply unit at IPR’s site as per Section: 8.5.
- vi. Installation and interface of BPS unit with other systems like input supply, control system interface, output connection etc. (Refer Sections: 8)
- vii. Perform the Site acceptance tests as per Section: 7.2.
- viii. Provide operational and instruction manuals with full technical details. (Refer Section:9.3)
- ix. Should provide training of the operation and maintenance for minimum 2 people at IPR.
- x. Should provide FAT & SAT Report with all test results, to the IPR before final acceptance
- xi. Technical support as per warranty clause

4 Technical Specifications

This section deals with the detailed technical specifications of the BPS unit. Bidders are required to provide corresponding specification value and information as requested against each specification. The technical specifications are categorized based on the functions.

S. No	Particulars	IPR Requirement	Bidder Specifications and Notes
4.1 Input Side Specifications			
4.1.1	Input Voltage	3-ph, 4 wire with Protective Earth, 415±10% Volts AC	
4.1.2	Input Frequency	50 Hz ± 3Hz	
4.2 Output Side Specifications			
4.2.1	Reference Type	Return conductor/lead should be isolated from ground for 500V	
4.2.2	Nominal Output	+35kV at 100mA, continuous duty	
4.2.3	Output Voltage Range	0kV to +35kV (max)	

4.2.4	Output Regulated Voltage Range	3.5kV to 35kV	
4.2.5	Voltage ripple (on full load)	350V _{pk-pk}	
4.2.6	Rise/Fall time (with prescribed Load Conditions)	1ms	
4.2.7	Voltage accuracy	± 350V	
4.2.8	Output Voltage Control Resolution	±700V (±2%)	
4.2.9	Max. overshoot /undershoot	±2 % of nominal value	
4.2.10	Settling time (with prescribed Load Conditions)	5ms	
4.2.11	Limiting Charge in case of short circuit at HV output (including 10m co-axial cable length)	≤ 100 mAs corresponding to 10J energy	
4.2.12	Self-Protection against short circuits, over voltage	Should be provided	
4.2.13	Control modes	Both Local and Remote (Refer Section: 9.1)	
4.2.14	Consecutive Pulse mode Operation	It is required that this power supply shall be able to operate in pulses ≤100ms with an interval of ≥25ms	

4.3 Control requirements at Front Panel

4.3.1	AC Input ON/OFF Control	To isolate unit from mains	MCCB/Switch/pushbutton with clear visual indication	
4.3.2	Local/Remote Mode	Mode selection	Selection Switch with key	
4.3.3	Emergency Shut-down	To Shut-off BPS Unit	Emergency Pushbutton with key	
4.3.4	O/P HV ON/OFF	To control Parameters With coarse and fine variation	HV ON/OFF Switch with clear visual indication	
4.3.5	O/P HV setting		Pushbuttons/Touchpad	
4.3.6	Power Supply Reset	To reset the unit to initial conditions	Pushbuttons/Touchpad	

4.4 Control Requirements at Remote Side

4.4.1	Output HV ON/OFF	Unit shall be turned ON/OFF using external signal	TTL Signal	
4.4.2	Power Supply Reset	External signal which will reset the unit to initial conditions	TTL Signal	
4.4.3	O/P HV Voltage control	External signal to control the HV O/P for Normal operation of HVPS	0-10 VDC (Linear)	

These remote signals should be galvanically isolated from power circuit.

4.5 Display/Indications on Front Panel Side

4.5.1	AC Mains I/P Status “ON/OFF”	AC Mains Status	
4.5.2	BPS Trip/Interlock Status	Health of Unit with a pilot	

			lamp	
4.5.3	Output HV “ON/OFF” Status		Output HV Condition with a pilot lamp	
4.5.4	Alarm		A continuous loud audible alarm shall be triggered in case of any fault/Trip.	
4.5.5	Industrial HMI Display		Common Screen of suitable size to display important parameters, Alarms, Temperature etc. of unit.	
4.6 Measurements, Metering and Monitoring Requirements at Front Side/Local				
4.6.1	Output High Voltage		Display of measured O/P parameters: Minimum Resolution to Nominal Values	
4.6.2	Output Current			
4.7 Protections, Alarm and Terminations				
4.7.1	Input Side		1. Over Voltage/Under Voltage 2. Soft start 3. Suitable breaker	
4.7.2	Output Side		1. Output Over Current 2. Output Over Voltage 3. Short Circuit protection (OV & OC Limits should be adjustable till 150% of set values)	
4.7.3	Alarm		1. Input OV/UV 2. Output Short circuit	
4.7.4	Interlocks	This interlocks shall be operated irrespective of the local or remote operation of the unit from an external controller.	Digital Inputs Provision of two numbers of separate interlocks TTL signals to turn-off the BPS unit externally.	
4.7.5	HV O/P terminations		On HV Bushings	
4.8 Load Specifications:				
Load bank shall also be the part of scope of supply complying with the technical specifications specified below. A parallel combination of high voltage resistance unit and high voltage capacitors with following specifications are considered to be an equivalent of Gyrotron body circuit as depicted in annexure. Load consists of sub-units as mentioned below:				
4.8.1	Technical Specifications of High Voltage Resistance Unit-1 : Qty 1 No.			
4.8.1.1	Operating Voltage	35kV		
4.8.1.2	Resistance	350 kΩ ± 10%		
4.8.1.3	Continuous Power rating	3.5 kW		
4.8.1.4	Ambient Temperature	~ 30° C		
4.8.1.5	Housing	IP 20-Powder Coated Sheet Steel		
4.8.1.6	Terminations	Corona free terminations		
4.8.1.7	Type	Non-Inductive		
4.8.1.8	Dimensions	Specify		
4.8.2	Technical Specifications of High Voltage Resistance Unit-2 : Qty 1 No.			

4.8.2.1	Operating Voltage	35kV	
4.8.2.2	Resistance	500 k Ω \pm 10%	
4.8.2.3	Continuous Power rating	2.5 kW	
4.8.2.4	Ambient Temperature	~ 30° C	
4.8.2.5	Housing	IP 20-Powder Coated Sheet Steel	
4.8.2.6	Terminations	Corona free terminations	
4.8.2.7	Type	Non-Inductive	
4.8.2.8	Dimensions	Specify	
4.8.3	Technical Specifications of High Voltage Capacitor Unit-2 : Qty 1 No.		
4.8.3.1	Operating Voltage	35kV (DC - 5kHz)	
4.8.3.2	Operation Type	Energy Storage/Filter	
4.8.3.3	Voltage Reversal	Bipolar (100%)	
4.8.3.4	Capacitance	1000pF \pm 10%	
4.8.3.5	Repetitive Peak current	\geq 50A	
4.8.3.6	Ambient Temperature	~ 30° C	
4.8.3.7	Encapsulation/Housing	Specify	
4.8.3.8	Terminations	Corona Free	
4.8.3.9	Dimensions	Specify	
4.8.4	Technical Specifications of High Voltage Capacitor Unit-2 : Qty 1 No.		
4.8.4.1	Operating Voltage	35kV (DC - 5kHz)	
4.8.4.2	Operation Type	Energy Storage/Filter	
4.8.4.3	Voltage Reversal	Bipolar (100%)	
4.8.4.4	Capacitance	500pF \pm 10%	
4.8.4.5	Repetitive Peak current	\geq 50A	
4.8.4.6	Ambient Temperature	~ 30° C	
4.8.4.7	Encapsulation/Housing	Specify	
4.8.4.8	Terminations	Corona Free	
4.8.4.9	Dimensions	Specify	

Table 1 Technical Specifications of BPS unit.

4.9 Desired Requirements

4.9.1	Computer	RS485/RS232 (<i>with complete command set</i>)
4.9.2	O/P Current threshold Set	Through Protocol (4.9.1)
4.9.3	Dimensions	<p>A compact unit is preferred;</p> <p>Ceiling dimensions 2000mm(W) X 2000mm(D) X 2200mm(H)</p> <p>A suitable chamber with dimensions of ~300 mm X ~300 mm X ~300mm(TBD) to be present at the cable terminations for crowbar arrangement</p>

4.10 Typical Expected Waveforms

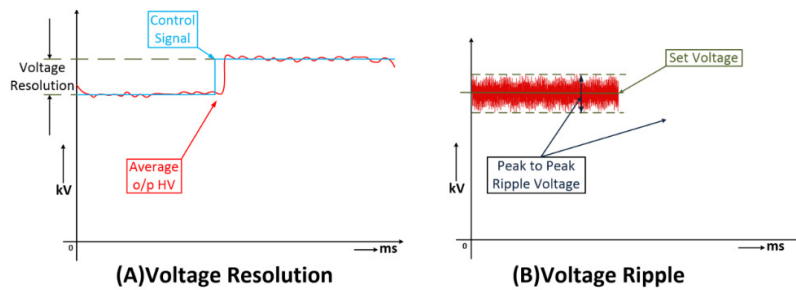

Figure 1 Representation of Output Voltage's Resolution and Ripple

5 Conceptual Technical Proposal

Bidder shall submit a brief conceptual technical proposal including major details such as GA drawing, BoM of key components, suggested spares etc. of offered topology, that meets the specified technical specifications (refer Section: 4) along with the bid. During the evaluation of technical bids, IPR shall review the submitted technical proposal and may seek further clarifications/discussions with bidder to ascertain feasibility or viability of the same. If the proposal is found to be incapable of meeting the technical specifications, the bid shall be technically disqualified.

6 Engineering Design Report

After the award of contract, supplier should submit an Engineering Design Report (EDR) for the body power supply based on the technical proposal submitted during the bid. This report shall include engineering design, detailed description of the system, detailed calculations(if applicable), GA drawings, simulation results(if any, and software used in simulation code) and standards followed, Quality Plan, Test Procedure, list of major components, list of spares, stage wise inspection and testing, factory and site acceptance testing procedure.

Though the information on the above specified design and interface requirements are to be submitted along with the EDR, but, if any such information is not fully finalized (FAT Template etc.) at the time of EDR submission, then a preliminary information can be provided in EDR and the updated content shall be submitted to IPR at the time of FAT intimation.

7 Acceptance Tests

7.1 Factory Acceptance Tests (FAT)

The following are some major tests that are to be performed by the supplier to demonstrate compliance of the BPS unit as per the contract specifications prior to the shipment. All the related test equipment, fixtures, measuring instruments, test-setup etc., shall be arranged by supplier. Supplier shall submit a FAT template to IPR for review and approval. The details of the test template and testing procedure shall be done on mutual agreement after the award of contract.

- A. **General Tests**
- B. **Functional Tests**
- C. **Control Checks**
- D. **Protection and Interlock Tests**
- E. **Parametric Tests**
- F. **Pulse Tests**
- G. **Load Tests (With RC Load)**

7.2 Site Acceptance Tests (SAT)

Assembly, Installation, Commissioning and Site Acceptance Tests are under the scope of Supplier. The SAT shall be performed in-line with FAT by the supplier (refer Section: 7.1) at IPR Laboratory. IPR at its discretion may prescribe all or a reduced subset of FAT tests at the IPR site.

8 Management Specifications

8.1 Project Execution Schedule

The required delivery schedule for all the deliverables is on or before **12 months** from the date of signature of contract. A preliminary project execution schedule which meets the overall delivery duration with major activities and milestones shall be submitted along with the bid. However, the bidder should submit a detailed project execution schedule which meets the targeted delivery time after award of contract. This project execution schedule may include; design, component procurements, manufacturing, FAT, delivery milestones and SAT etc.

Milestone	Mile Stone / Activity	Time to be completed
MSO	Award of Contract	T0
MSX	Delivery at IPR Site	Td ≤ T0+12M
Td: Delivery Time; M: Months		

Table 2 Project Execution Schedule

8.2 Quality Plan

The BPS unit should be manufactured in conformance with the international and/or national standards/codes to assure the quality and reliability of the BPS unit. Bidder shall prepare a Quality plan or a manufacturing inspection plan which ensures the operational quality of the deliverable items under this contract. The same shall be submitted to IPR for its review and approval. Quality plan or manufacturing inspection plan shall provide details of inspections/tests that will be carried out at various stages of the contract like design, engineering, procurements, manufacturing, assembly and testing.

8.3 Factory Acceptance tests (FAT)

Factory Acceptance Tests (FAT) shall be performed by the supplier to demonstrate compliance of the BPS unit as per contract specifications before effecting the shipment. (Refer Section: 7).

8.3.1 FAT Procedure and Technical Details

The supplier shall prepare an acceptance test procedure (ATP) for FAT with technical details (such as test setup and test templates etc.) in line with the specified FAT test requirements (refer Section: 7). This acceptance test procedure shall be submitted to IPR for review and approval well before the FAT.

8.3.2 FAT Report

A FAT test report consisting of detailed test results shall be prepared by the supplier and shall be submitted to IPR for Review and approval. .

8.4 Operating and Instruction Manual

The supplier shall submit an operating and instruction manual consisting of installation, operation, maintenance and troubleshooting instructions (refer annexure).

8.5 Material Dispatch/Packaging and Delivery

After the review and approval of FAT Report, a Dispatch Clearance Note shall be issued to the supplier by IPR. All the deliverables (hardware and document deliverables) shall be dispatched only after receiving a dispatch clearance note from IPR. However, a mere clearance issued by IPR will not relieve the supplier from the liability of proper functioning of BPS unit at IPR Laboratory.

Appropriate safe packing, transportation (Including Insurance) to IPR site are under the scope of the supplier, which shall include (but not limited to) a necessary list of documentation and appropriate packing, markings, labelling for the deliverables items. It must be noted that IPR shall not be liable for any of the damages caused during transit of the deliverables. The detailed packaging and transportation scheme shall be submitted to IPR well in advance.

8.5.1 Site Description

The laboratory/delivery site is located in the Institute for Plasma Research Campus, near Indira Bridge, Mother dairy, Bhat, Gandhinagar-382428. The Laboratory, where the equipment is to be installed is situated at a **height of 13.72m** from the road/ground level in IPR Laboratory Building.

8.6 Site Acceptance tests (SAT)

Assembly, Installation, Commissioning and Site Acceptance Tests are under the scope of Supplier. The SAT shall be performed in-line with FAT by the supplier (refer Section: 7.1) at IPR Laboratory. IPR at its discretion may prescribe all or a reduced subset of FAT tests at the IPR site.

8.6.1 SAT Report

After completion of SAT, a test report consisting of detailed test results shall be prepared by the Supplier. The representatives of IPR and the Supplier shall jointly sign the SAT test report. Further a Minutes summarizing the SAT tests shall be prepared and signed jointly by the representatives of Supplier and IPR.

8.7 Final Acceptance

A Final acceptance note shall be issued by IPR to the Supplier after successful completion of SAT (after resolving issues completely, if any) at site. The date of issuance of final acceptance note shall be considered as the date of final acceptance.

8.8 Warranty

Supplier should provide a minimum of one year standard warranty for all the deliverables (BPS unit and all its accessories) thereof from the date of final acceptance issued by IPR (refer Section: 8.7).

Additionally, an optional one year extended warranty from the date of expiry of above specified minimum warranty is to be quoted separately.

9 Annexures

9.1 Application Description

Introduction:

Gyrotron is a vacuum electronic device employed for generating high power high frequency RF power. Major specifications of the Gyrotron tube are 1MW Continuous, 170GHz. This Gyrotron is employed to aid the plasma heating application. In order to assist in the acceleration of electron beam two different power supplies are used (one of which is under this scope of supply) as highlighted in the below figures. The main function of the Body power supply unit (**under the scope of supply**) is to aid in initiating high accelerating potentials in the Gyrotron tube. In general, the BPS unit is subjected to operate in continuous mode. However there exists a strong possibility that this unit be operated in Pulse mode, where the minimum pulse width would be greater than rise and fall times combined with due margins.

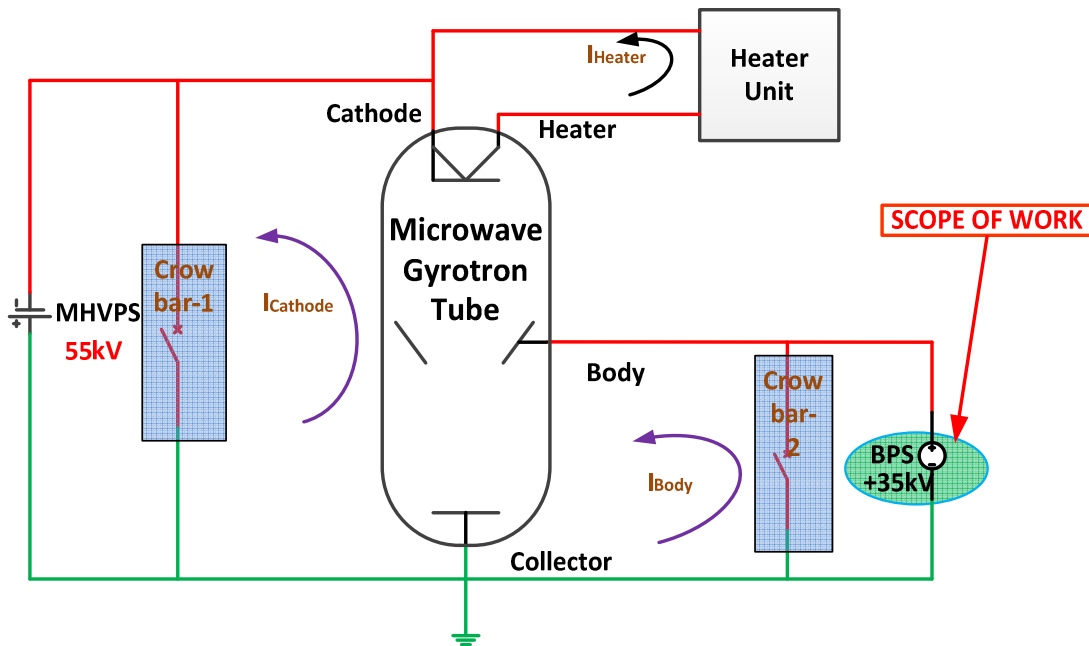

Figure 2 Electrical Circuit arrangement of the Gyrotron Tube

Equivalent Circuit:

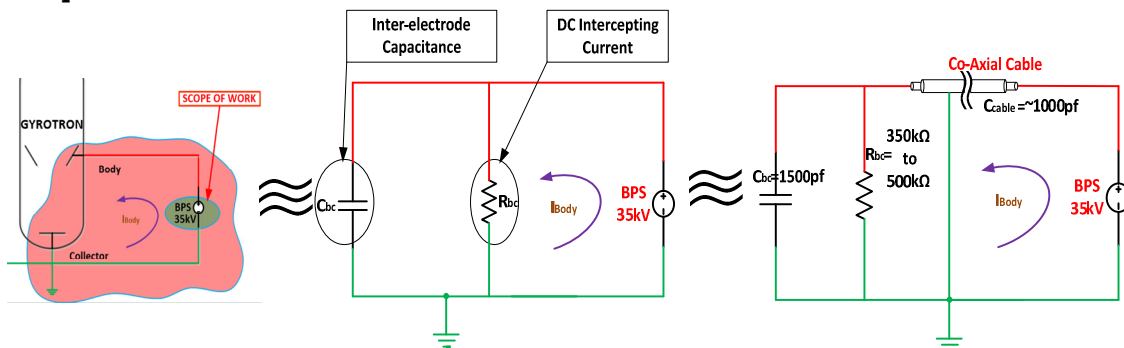

Figure 3 Equivalent load circuit for Body Power Supply Unit

Description:

A close approximate equivalent of Gyrotron's body circuit has been realized using a parallel combination of resistive and capacitive load banks (**are in the scope of supply**). Here the

resistive part is emulated for intercepting current with resistance values of 350kΩ/500kΩ (two separate units) and to realize body to collector inter-electrode capacitance, a capacitance of 2500pf (1500pf load + ~1000pf cable capacitance) shall be used.

Operation of BPS unit:

The power supply will be operated in DC-mode (continuous), Pulse-mode. As depicted in the below figures the output of power supply unit will be pulsed as specified in section 4 with RC loads. The **rise and fall times** of the output voltage should be **1ms** irrespective of operating mode.

A: DC Mode Operation

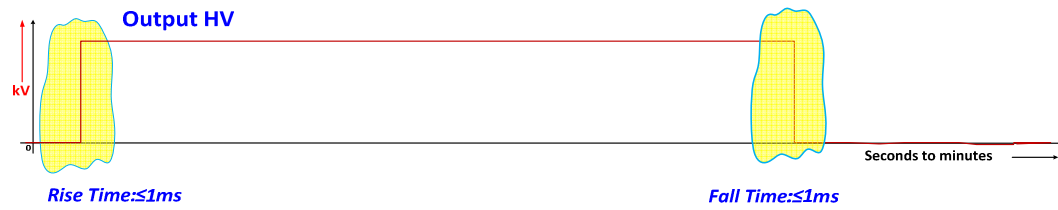

B: Pulsed Mode Operation

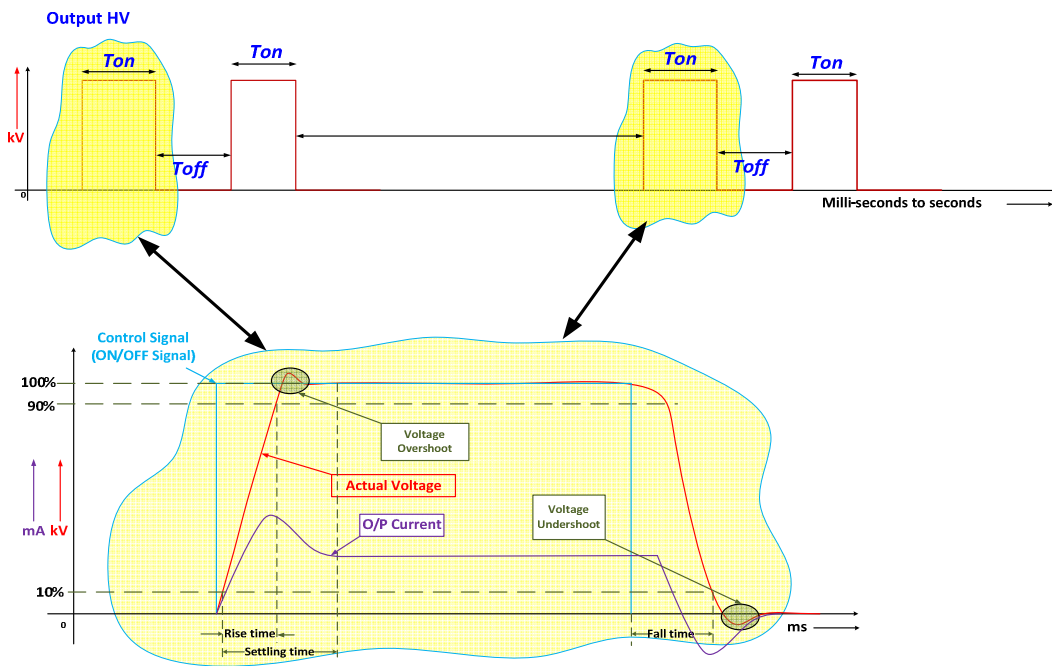

Figure 4 Timing Definitions & required Waveforms of BPS Unit with RC Load

Note1: These expected waveforms across the load and are illustrated to portray the actual conditions with the Gyrotron’s body circuit. In practice voltage and currents waveforms may differ slightly with the depicted ones; however the unit must comply with all other specifications.

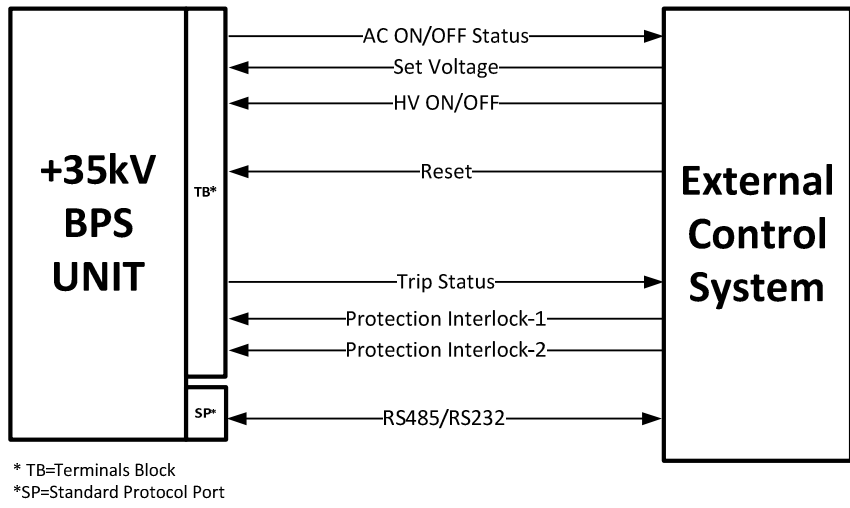

Figure 5 Control Interface of BPS Unit

Operating Modes

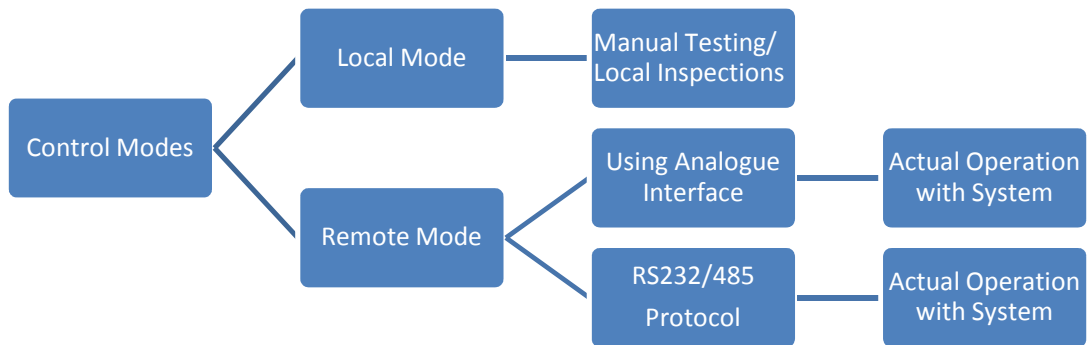

Figure 6 Operation diagram of the BPS Unit

9.1.1 In remote mode BPS unit shall be operated with Analog signals or Protocol through external controller.

I. Local Mode

In this mode, all the control functions at the front panel should be enabled. BPS unit shall be operated manually in person with front panel controls and the unit shall comply with the control requirements specified in Section: 4.

II. Remote Mode

In this mode, the BPS unit shall be operated remotely through external controller. Interface shall be of hardwired signal and/or through RS485/RS232. In this mode all the front panel controls should be disabled apart from selector switch and emergency switch. The BPS unit shall comply with the specifications as specified in Section: 4

Note2: In case of any external and or internal event, BPS should able to respond to the external interlocks and shall turn-off the power supply.

9.1.2 Irrespective of Operating mode the following functions should be available:

- Emergency pushbutton's control should be active all the time
- Protection interlock's control should be active all the time
- All monitoring analogue signals should be present at remote side.
- Output measurement data should be available through protocol (RS232/RS485)

9.2 Guidelines

These are some guidelines that bidder shall be informed while executing the project.

9.2.1 General

- 9.2.1.1 The bidder holds the responsibility to design, manufacturing, factory testing, installation and commissioning at the IPR, (purchaser) site as per scope.
- 9.2.1.2 The BPS unit shall have a dedicated controller either of DSP/FPGA/any other type of advanced controller (EXCLUDING microcontrollers of 8051 family) capable of meeting the specified functional specifications without failure.

9.2.2 Mechanical

- 9.2.2.1 Since it is a custom requirement there isn't any rigid requirements on the size of unit however we prefer a BPS unit which sizes around the dimensions of a standard cubicle (~1.2m wide x ~1.5m depth x ~1.8 m height, however this is NOT MANDATORY), for ease of operation and handling.
- 9.2.2.2 The BPS unit structure shall be made up of rigid and self-supporting structure of suitable steel profiles and shall be free of sharp edges/corners. The structural strength of the unit shall be such as to withstand its ultimate mechanical load (with all the individual units mounted) without any deformity. The base of unit shall ensure uniform floor loading. The gauge of steel that is used for the fabrication of unit shall be not less than 2.5 mm (minimum).
- 9.2.2.3 Lifting facilities shall be provided by removable eyebolt located at the top of the unit or by any other means which ensures the portability. Top of the unit shall be fully covered except for ventilation and/or cable entries. The necessary arrangement for fixing the unit on the floor shall also be provided.
- 9.2.2.4 The sides shall have suitable ventilating arrangements. Each air flow vent shall be covered by a grill to prevent the entry of foreign material larger than 2mm. The front and rear doors (if provided) shall be of hinged type and shall have proper arrangement for ventilation.
- 9.2.2.5 BPS unit shall have all the common visual alarms and meters shall be clearly visible. In case of a door arrangement on the front side of unit, all the meters and alarm indications are permitted, however, the fixtures on the door shall not restrict the movement of door in any way.
- 9.2.2.6 BPS unit shall be designed for easy maintenance and installation. The unit mounting

arrangement shall be such as to provide easy access from front, rear and top for installation and maintenance activities.

9.2.2.7 The unit shall be made standalone with a rigid framework with bottom clearance of 100 mm for ease of transportation.

9.2.2.8 All the doors of the BPS unit should be equipped with the cabinet locks with keys (either distinctive or same for all doors) no other type like square, triangular, socket type etc., are not allowed. All the doors shall be provided with a neoprene rubber gasket to make the panel's compartments dust proof.

9.2.2.9 Cooling: Ample number of exhaust fans with proper ratings should be employed; these fans should be of die-cast aluminium painted black with grills.

9.2.2.10 Unit shall have suitable size about ~300mm X ~300 mm X~300mm (TBD) amount of for keeping arc current limiting resistor and protective devices at the cable termination chamber.

9.2.3 **Electrical**

9.2.3.1 All the termination (electrical cables entries) points shall be easily accessible to reduce the complexity while operation, alteration and maintenance activities.

9.2.3.2 All the current carrying parts shall be separated by physical barriers to ensure safety. All the terminals except AC earth shall be electrically isolated. Fuses and Circuit-breakers provided shall be easily accessible and properly rated so as for easy replacement.

9.2.3.3 Input terminals of the unit shall be clearly marked as R, Y, and B, N, and E and Output DC terminals (HV) as + ve and -ve respectively.

9.2.3.4 It must be noted that all visual indications shall be placed at proper height on the BPS unit so as the indications shall be visible and reachable for operating personnel.

9.2.3.5 It is preferred and suggested to have all the display instruments to be of digital type and with a measurement class of 0.5 or less ($\leq 0.5\%$ accuracy class) unless and otherwise specified and in case of unavailability; other alternatives shall be used with the due approval of IPR.

9.2.3.6 There should be a clear and prominent "DANGER" Marking at the termination block.

9.2.3.7 All insulated conductors except those within the confines of a PCB assembly, shall be of the suitable ratings, which are enough to withstand the maximum current and voltage during overload and/or fault/abnormal conditions.

9.2.3.8 All wiring shall be neatly secured in position and adequately supported. Where cables/wires pass through the metal panel, suitable size of cable glands shall be used. All the wires and cables used shall be of low smoke zero halogen fire retardant as per IS1554 and IS 694 or IEC 61034 with latest amendments and they shall be properly rated to prevent excessive heating. Proper indication on cable shall be provided for all the cables.

9.2.3.9 The associated AC, DC connections, control, alarms and interface cable connecting the unit shall be connected/disconnected easily without causing any interruption in the supply and damage to load or other circuits. In case of Modular systems, the units shall be removable from the front of the unit only. All live parts AC, DC, and control, alarm and monitoring cables interconnecting the units shall be easily disconnected by plugs or connector.

9.2.3.10 The bidder shall ensure good workmanship while manufacturing/fabrication process of the BPS unit.

9.2.4 **Key Considerations of Body Power Supply Unit**

9.2.4.1 The BPS unit should be of industrial grade and robust in nature, which shall endure all the harsh high voltage conditions.

9.2.4.2 Suitably rated protective devices and filters shall be employed against the input power lines voltage transients and to reduce harmonics in power lines.

9.2.4.3 Soft-start shall be present on the input side to alleviate turn-on stress.

9.2.4.4 The BPS unit shall manage the drifts associated with temperature in control amplifiers,

feedback loops, dividers, current shunts, control and monitoring signals, so as to ensure performance integrity.

- 9.2.4.5 If required an appropriate sized housekeeping power supply shall be used to isolate sensitive circuits from the harsh power line circuit.
- 9.2.4.6 All the surfaces/physical layouts of components/systems which are exposed high voltage should be field gradient i.e., the electric field “E” over the components should not create a dense field which shall trigger the corona/PD over the respective geometries.
- 9.2.4.7 Components and Cables crossing high voltage sections should not create intense voltage fields near the boundaries. Usage of several insulating materials must be avoided to minimize interfaces.
- 9.2.4.8 Suitable type of ventilating ducts (exhaust fan openings), should be chosen to avoid contamination at the HV sections
- 9.2.4.9 All the insulating materials should be de-rated with due margins, as per the maximum electrical stresses. Boundaries of HV section and LV section must be assigned and a safe electric field gradient must be maintained throughout the unit.
- 9.2.4.10 Arcing Phenomenon: The BPS unit should tolerate the arcing across its output terminals. Suitable protective devices/components should be incorporated to limit the magnitude of arc current (through a current limiting resistor) and di/dt (through an inductor) without deviating from the technical specifications.
- 9.2.4.11 All the solid-state devices shall be rated/de-rated with the repetitive arcing phenomena in consideration. This arcing might be frequent during the initial testing period (conditioning of Gyrotron tube) and unit’s performance should not get degraded. BPS unit shall ensure that, if an arc is occurred across its terminals, it shall ensure path of arcing current completes with in its loop and shall not damage the other low voltage electronic systems inside/nearby.
- 9.2.4.12 Creepage and Clearances: Generally in accordance with IEC or IS standard.
- 9.2.4.13 High Voltage Diagnostics: The critical characteristics like bandwidth, response, full-scale values, impedances etc., of the measuring units/transducers such as high voltage dividers, DC and pulse current transducers should be appropriately rated to meet/or exceed the technical specifications.
- 9.2.4.14 Grounding/Earthing: The power supply unit shall have suitable grounding, which ensures safer operation of the system under normal and abnormal conditions. All the lines of power, control (analog and digital) shall be properly terminated to their respective returns.

9.3 Operation and Instruction Manual

The supplier shall submit/furnish a set of documents/technical literature in English language with complete layout, GA drawings, detailed block diagrams and circuit diagrams of its assemblies with test voltages at different test points of the unit. All aspects of installation, operation, maintenance and troubleshooting as specified below shall be covered in this manual.

- **Safety measures to be observed in handling of the equipment.**
- **Illustration of internal and external mechanical parts.**
- **Precautions at the time of installation, operation and maintenance**
- **Procedure with flowchart for trouble shooting and sub-assembly replacement**
- **Procedures for trouble shooting, replacement and routine/preventive maintenance**
- **Steps of remedial measures for troubleshooting the faults.**
- **Required Test Jigs and fixtures.**
- **Test Instruments, Test fixtures, accessories and tools required for maintenance and repair**
- **List of replaceable parts used with the sources of procurement**
- **A table giving details of sizes and dimension of cables used**
- **Remedial steps for typical faults**

Compliance Sheet

Technical Compliance Sheet

S. No	Particulars	IPR Requirement	Bidder Specifications and Notes
1 Input Side Specifications			
1.1.1	Input Voltage	3-ph, 4 wire with Protective Earth, 415±10% Volts AC	
1.1.2	Input Frequency	50 Hz ± 3Hz	
1.2 Output Side Specifications			
1.2.1	Reference Type	Return conductor/lead should be isolated from ground for 500V	
1.2.2	Nominal Output	+35kV at 100mA, continuous duty	
1.2.3	Output Voltage Range	0kV to +35kV (max)	
1.2.4	Output Regulated Voltage Range	3.5kV to 35kV	
1.2.5	Voltage ripple (on full load)	350V _{pk-pk}	
1.2.6	Rise/Fall time (with prescribed Load Conditions)	1ms	
1.2.7	Voltage accuracy	± 350V	
1.2.8	Output Voltage Control Resolution	±700V (±2%)	
1.2.9	Max. overshoot /undershoot	±2 % of nominal value	
1.2.10	Settling time (with prescribed Load Conditions)	5ms	
1.2.11	Limiting Charge in case of short circuit at HV output (including 10m co-axial cable length)	≤ 100 mAs corresponding to 10J energy	
1.2.12	Self-Protection against short circuits, over voltage	Should be provided	
1.2.13	Control modes	Both Local and Remote (Refer Section: 9.2)	
1.2.14	Consecutive Pulse mode Operation	It is required that this power supply shall be able to operate in pulses ≤100ms with an interval of ≥25ms	
1.3 Control requirements at Front Panel			
1.3.1	AC Input ON/OFF Control	To isolate unit from mains	MCCB/Switch/pushbutton with clear visual indication
1.3.2	Local/Remote	Mode selection	Selection Switch with key

	Mode			
1.3.3	Emergency Shut-down	To Shut-off BPS Unit	Emergency Pushbutton with key	
1.3.4	O/P HV ON/OFF	To control Parameters With coarse and fine variation	HV ON/OFF Switch with clear visual indication	
1.3.5	O/P HV setting		Pushbuttons/Touchpad	
1.3.6	Power Supply Reset	To reset the unit to initial conditions	Pushbuttons/Touchpad	
1.4 Control Requirements at Remote Side				
1.4.1	Output HV ON/OFF	Unit shall be turned ON/OFF using external signal	TTL Signal	
1.4.2	Power Supply Reset	External signal which will reset the unit to initial conditions	TTL Signal	
1.4.3	O/P HV Voltage control	External signal to control the HV O/P for Normal operation of HVPS	0-10 VDC (Linear)	
These remote signals should be galvanically isolated form power circuit.				
1.5 Display/Indications on Front Panel Side				
1.5.1	AC Mains I/P Status “ON/OFF”		AC Mains Status	
1.5.2	BPS Trip/Interlock Status		Health of Unit with a pilot lamp	
1.5.3	Output HV “ON/OFF” Status		Output HV Condition with a pilot lamp	
1.5.4	Alarm		A continuous loud audible alarm shall be triggered in case of any fault/Trip.	
1.5.5	Industrial HMI Display		Common Screen of suitable size to display important parameters, Alarms, Temperature etc. of unit.	
1.6 Measurements, Metering and Monitoring Requirements at Front Side/Local				
1.6.1	Output High Voltage		Display of measured O/P parameters: Minimum Resolution to Nominal Values	
1.6.2	Output Current			
1.7 Protections, Alarm and Terminations				
1.7.1	Input Side		1. Over Voltage/Under Voltage 2. Soft start 3. Suitable breaker	
1.7.2	Output Side			1. Output Over Current

			2. Output Over Voltage 3. Short Circuit protection (OV & OC Limits should be adjustable till 150% of set values)	
1.7.3	Alarm		1. Input OV/UV 2. Output Short circuit	
1.7.4	Interlocks	This interlocks shall be operated irrespective of the local or remote operation of the unit from an external controller.	Digital Inputs Provision of two numbers of separate interlocks TTL signals to turn-off the BPS unit externally.	
1.7.5	HV O/P terminations		On HV Bushings	
<p>1.8 Load Specifications: Load bank shall also be the part of scope of supply complying with the technical specifications specified below. A parallel combination of high voltage resistance unit and high voltage capacitors with following specifications are considered to be an equivalent of Gyrotron body circuit as depicted in annexure. Load consists of sub-units as mentioned below:</p>				
1.8.1	Technical Specifications of High Voltage Resistance Unit-1; Qty: 1 No			
1.8.1.1	Operating Voltage		35kV	
1.8.1.2	Resistance		350 kΩ ± 10%	
1.8.1.3	Continuous Power rating		3.5 kW	
1.8.1.4	Ambient Temperature		~ 30° C	
1.8.1.5	Housing		IP 20-Powder Coated Sheet Steel	
1.8.1.6	Terminations		Corona free terminations	
1.8.1.7	Type		Non-Inductive	
1.8.1.8	Dimensions		Specify	
1.8.2	Technical Specifications of High Voltage Resistance Unit-2; Qty: 1 No			
1.8.2.1	Operating Voltage		35kV	
1.8.2.2	Resistance		500 kΩ ± 10%	
1.8.2.3	Continuous Power rating		2.5 kW	
1.8.2.4	Ambient Temperature		~ 30° C	
1.8.2.5	Housing		IP 20-Powder Coated Sheet Steel	
1.8.2.6	Terminations		Corona free terminations	
1.8.2.7	Type		Non-Inductive	
1.8.2.8	Dimensions		Specify	
1.8.3	Technical Specifications of High Voltage Capacitor Unit-2; Qty: 1 No			
1.8.3.1	Operating Voltage		35kV (DC - 5kHz)	
1.8.3.2	Operation Type		Energy Storage/Filter	
1.8.3.3	Voltage Reversal		Bipolar (100%)	
1.8.3.4	Capacitance		1000pF ± 10%	
1.8.3.5	Repetitive Peak current		≥ 50A	

1.8.3.6	Ambient Temperature	~ 30° C	
1.8.3.7	Encapsulation/Housing	Specify	
1.8.3.8	Terminations	Corona Free	
1.8.3.9	Dimensions	Specify	
1.8.4	Technical Specifications of High Voltage Capacitor Unit-2; Qty: 1 No		
1.8.4.1	Operating Voltage	35kV (DC - 5kHz)	
1.8.4.2	Operation Type	Energy Storage/Filter	
1.8.4.3	Voltage Reversal	Bipolar (100%)	
1.8.4.4	Capacitance	500pF ± 10%	
1.8.4.5	Repetitive Peak current	≥ 50A	
1.8.4.6	Ambient Temperature	~ 30° C	
1.8.4.7	Encapsulation/Housing	Specify	
1.8.4.8	Terminations	Corona Free	
1.8.4.9	Dimensions	Specify	
1.9 Desired Requirements			Bidder Specifications and Notes
1.9.1	Computer	RS485/RS232 (<i>with complete command set</i>)	
1.9.2	O/P Current threshold Set	Through Protocol (4.5.6)	
1.9.3	Dimensions	A compact unit is preferred; Ceiling dimensions 2000mm(W) X 2000mm(D) X 2200mm(H)	
		A suitable chamber with dimensions of ~300 mm X ~300 mm X ~300mm(TBD) to be present at the cable terminations for crowbar arrangement	

Authorised Signatory

Official Seal

Date :-

SECTION 'D'

FORMAT FOR SUBMISSION OF PART-I (TECHNO-COMMERCIAL) OF THE TENDER.

TENDER FORM

Telephone Nos. : PART-I (TECHNO-COMMERCIAL)
OF TENDER NO. IPR/TPT/TN/PUR/F/17-18/31
Last date for receipt 28th Feb, 2018 at 13:00 hrs. IST.
Fax No. : Due date for opening 28th Feb, 2018 at 15:30 Hrs. IST
E-mail :
Tenderer's Offer No. _____ Date _____

FROM

M/s. _____

To
The Purchase Officer
Institute for Plasma Research
Nr. Indira Bridge
Bhat, Gandhinagar-382428
Gujarat
INDIA

Dear Sir,

1. I/We have gone through the tendering conditions pertaining to the Two-Part Tender and General Conditions of Contract and Special Conditions of Contracts contained in Form No. IPR-FP-12. I/we hereby agree to supply the stores conforming to the tender specifications incorporated in Section "C" of the tender documents.
2. You will be at liberty to accept any one or more of the items of stores offered by us and I/we shall be bound to supply you the stores as may be specified in the Purchase Order/Contract.
3. Deviations to Technical specifications contained in Section 'C' of the tender documents are detailed in annexure-A to the tender form while deviations proposed to the General Special Conditions of Contract are detailed in Annexure-B to this tender. Price applicable for the stores are indicated separately in a sealed envelope marked as Part-II (Price) of the tender.
4. I/We are also enclosing herewith all the leaflets catalogue etc. pertaining to the stores offered.

Encl:

Yours faithfully

Stamp and Signature of the Tenderer

SECTION 'E'

FORMAT FOR SUBMISSION OF PART-II – PRICE BID (PRICE ALONE) OF THE TENDER.

PRICE BID FORMAT

(Bidders are requested to offer their price in the following format)

“Design, Manufacturing, Testing & Supply of +35 kV, 100mA Fast Responding High Voltage DC Power Supply as per technical specifications mentioned in our tender documents”

TENDER NOTICE No. IPR/TPT/TN/PUR/F/17-18/31 DATED 27-12-2017

(specify the currency)

Sr. No	Description	Quantity	Unit cost	Total price
1	“Supply of +35 kV, 100mA Fast Responding High Voltage DC Power Supply as per technical specifications mentioned in our tender documents.”	1 No.		
2.	Load bank consisting of load elements as per technical specifications and details mentioned in the tender documents section-C/4.8	1 Set.		
3.	Recommended Spares / Accessories (if any) , (add separate sheet as required)			
4.	One year additional warranty (Optional)	--		
Total FOB/FCA named Airport/Seaport/Place Price.....				
5.	Installation and Commissioning Charges (Lumpsum) (if any)	1 Job		
Total Offered / Quoted Price				

	Indicate percentage (Except Freight)			
	Percentage	Included	Excluded	Not Applicable
Packing and Forwarding				
Insurance				
Customs Duty				
Goods & Services Tax				
Description	Vendor's Terms			
Place of Delivery				
Warranty				
Payment Terms				
Delivery Schedule				
Validity				
Any Other Terms				

Place :

Date :

Signature of Bidder with Seal

TENDER FORM

Telephone Nos. :

Tenderer's Offer No. _____ Date _____
PART-II (PRICE-BID)
OF TENDER NO. IPR/TPT/TN/PUR/F/17-18/31

Fax No. :

E-mail :

FROM

M/s. _____

To

The Purchase Officer
Institute for Plasma Research
Nr. Indira Bridge
Bhat, Gandhinagar-382428
Gujarat
INDIA

Dear Sir,

In response to your invitation and as per your tendering and contracting conditions, the price and other related commercial conditions applicable for the scope of supply contained in Part-I (Techno-Commercial) of our tender are indicated in the format at annexure "A" to this tender.

We hereby agree to abide by your terms and conditions of contract contained in section 'B' of this tender document. Deviations to your contract conditions are brought out separately in Annexure 'B' to this tender.

We hereby agree to keep the price valid for your acceptance for a period of 120 days from the date of actual opening of Part-II (Price) of the tender.

Yours faithfully,

Stamp and Signature of the Tenderer